



# WORLDWIDE ELECTRIC MOTOR DATA SHEET

## PEWWE250-18-449TC



HORSEPOWER	250		
RPM / POLES	1800 / 4		
VOLTAGE / PHASE	460 V / 3		
FRAME	449TC		
ENCLOSURE / DEGREE OF PROTECTION	TEFC / IP55		
FREQUENCY	60 HZ		
FULL LOAD SPEED	1790 RPM		
SERVICE FACTOR	1.15		
INSULATION CLASS	F		
FULL LOAD AMPS	280 A		
LOCKED ROTOR AMPS (STARTING)	1825 A		
NO LOAD CURRENT	91.5 A		
NEMA CODE LETTER	G		
EFFICIENCY / POWER FACTOR	<u>LOAD</u>	<u>EFF.</u>	<u>P.F.</u>
	100 %	96.2%	0.87
	75 %	96.3%	0.84
	50 %	95.8%	0.75
DUTY CYCLE	S1 / Continuous		
TORQUE	<u>FULL LOAD</u>	<u>LRT</u>	<u>BDT</u>
	733 lb.ft.	200%	260%
SLIP	0.56 %		
NEMA DESIGN	B		
MOMENT OF INERTIA	82.7 lb.ft. <sup>2</sup>		
MAX. TIME LOCKED ROTOR (Hot)	11 Seconds		
SOUND PRESSURE LEVEL	83 dB (A)		
MAX. AMBIENT TEMPERATURE	40° C		
MAX. ELEVATION	3300 Ft.		
TEMPERATURE RISE (At Full Load)	80° C		
DE BEARING	6320 C3		
ODE BEARING	6320 C3		
REGREASING INT. - DE BEARING	1,300 Hours		
REGREASING INT. - ODE BEARING	1,800 Hours		
GREASE TYPE	LGHP2 (SKF)		
MOUNTING	F1		
ROTATION	Bi-Directional		
SHAFT MATERIAL	4140 Carbon Steel		
INVERTER RATING	10:1 CT / 20:1 VT PWM Type		
CONNECTION DIAGRAM	460 V - 6 Lead Δ		
APPROXIMATE WEIGHT	2649 lbs.		





# WORLDWIDE ELECTRIC MOTOR DRAWING

## PEWWE-449TC

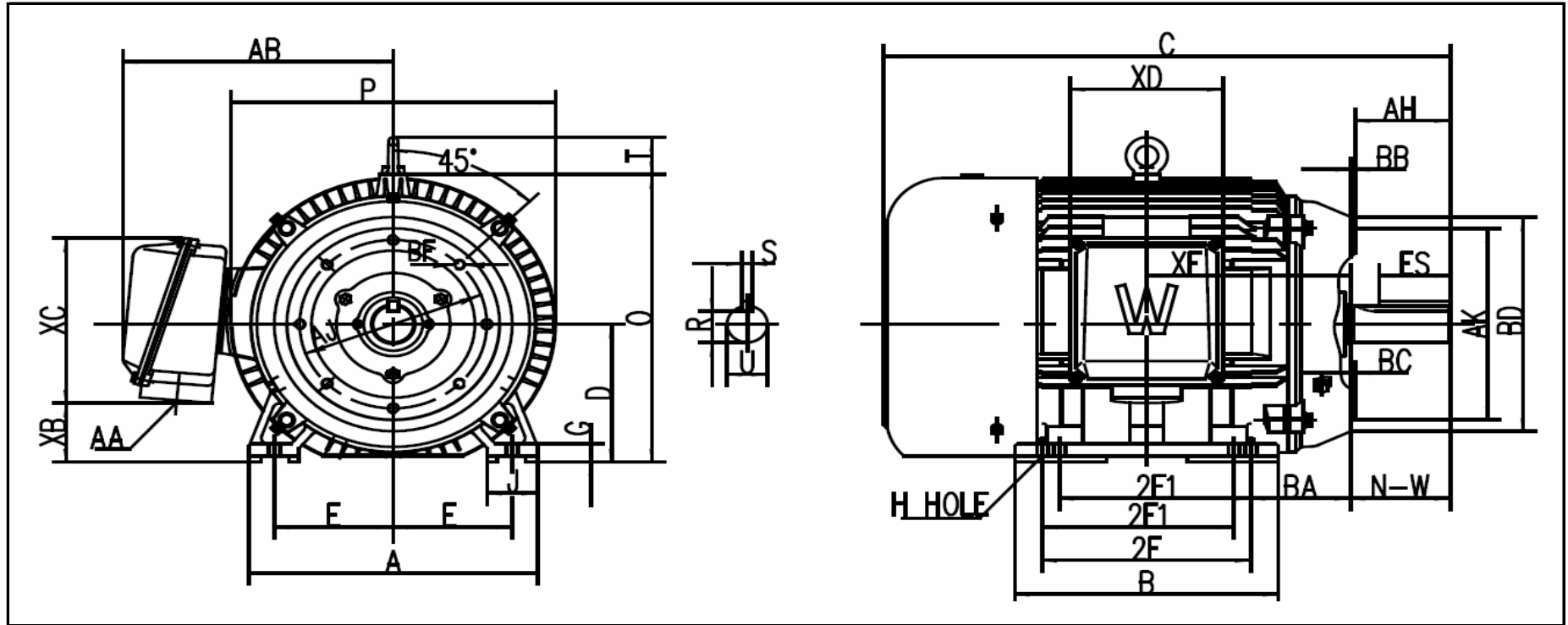

DIMENSIONS - INCHES

MOUNTING					A	B	C	D	G	J	P	O	T	AB
E	2F1	2F2	H	BA										
9	-	25	0.81	7.5	22	31	58	11	1.58	3.4	23.5	23	4.25	19.5

KEY		KEYSET	FLANGE				SHAFT		TERMINAL BOX					
S	ES	R	AK	AJ	BF	BB	BD	N-W	U	AA	XB	XC	XD	XE
0.875	7	2.88	16	16	5/8 - 11	0.25	18	8.5	3.375	2 x 3	4.87	12	11.5	23.65

REVISED - 10/19/18