

MODEL NUMBER	IEEE60-18-364T		
HORSEPOWER	60		
RPM / POLES	1800 / 4		
VOLTAGE / PHASE	460 / 3		
FRAME	364T		
ENCLOSURE / DEGREE OF PROTECTION	TEFC / IP56		
FREQUENCY	60 HZ		
FULL LOAD SPEED	1780 RPM		
SERVICE FACTOR	1.15		
INSULATION CLASS	F Class N Varnish		
FULL LOAD AMPS; 460	69.9 A		
LOCKED ROTOR CURRENT (% Full Load)	670 %		
NEMA CODE LETTER	G		
EFFICIENCY / POWER FACTOR	<u>LOAD</u>	<u>EFF.</u>	<u>P.F.</u>
	100 %	95.0 %	85.0 %
	75 %	95.1 %	81.9 %
	50 %	93.2 %	74.1 %
DUTY CYCLE	S1 / Continuous		
TORQUE	<u>FULL LOAD</u>	<u>LRT</u>	<u>BDT</u>
	178.1 lb.ft	150 %	220 %
NEMA DESIGN	B		
MOMENT OF INERTIA	<u>LOAD (Max.)</u>	<u>MOTOR</u>	
	616.991 lb.ft ²	17.640 lb.ft ²	
SOUND PRESSURE LEVEL (No Load 1 M From Motor)	82 dB(A)		
MAX. SHAFT VIBRATION	0.08 In/Sec – Peak Velocity		
NUMBER OF STARTS (Hot / Cold)	2 Hot / 3 Cold		
MAX. AMBIENT TEMPERATURE	40° C		
MAX. ELEVATION	3300 Ft. Above Sea Level		
TEMPERATURE RISE (At Full Load)	80° C		
DRIVE-END BEARING	6314C3		
OPPOSITE DRIVE-END BEARING	6213C3		
BEARING SEAL TYPE	ProTech™ IP66 Labyrinth On DE and ODE		
GREASE TYPE	Mobil Polyrex EM		
MOUNTING	F1 (F2 Suitable), W6, W8, B3, V5, V6		
ROTATION	Bi-Directional		
APPROXIMATE WEIGHT	780 lbs		
AREA CLASSIFICATION	Class I, Division 2, Groups A, B, C, D, T3A		
PAINT	Epoxy		
INVERTER RATING	10:1 CT / 1000:1 VT		
INSULATION TYPE	Hyundai Inverter Shield, Meets NEMA MG1 Part 31		
SPECIFICATION - In Accordance With	IEEE-841, Version 2009, NEMA, CSA		



CC 038A



본 도면은 현대중공업(주) 재산이며 복제할 수 없습니다 (취급유의)

THIS DRAWING IS PROPRIETARY TO HEECO. NO PART OF THIS DRAWING MAYBE REPRODUCED WITHOUT THE PERMISSION OF HHI.

		IEEE841 TEFC THREE PHASE INDUCTION MOTOR		TYPE	PLP Cast iron frame
FRAME SIZE	OUTPUT(HP)	POLES	Hz	TIME RATING	
364T			60	CONT	

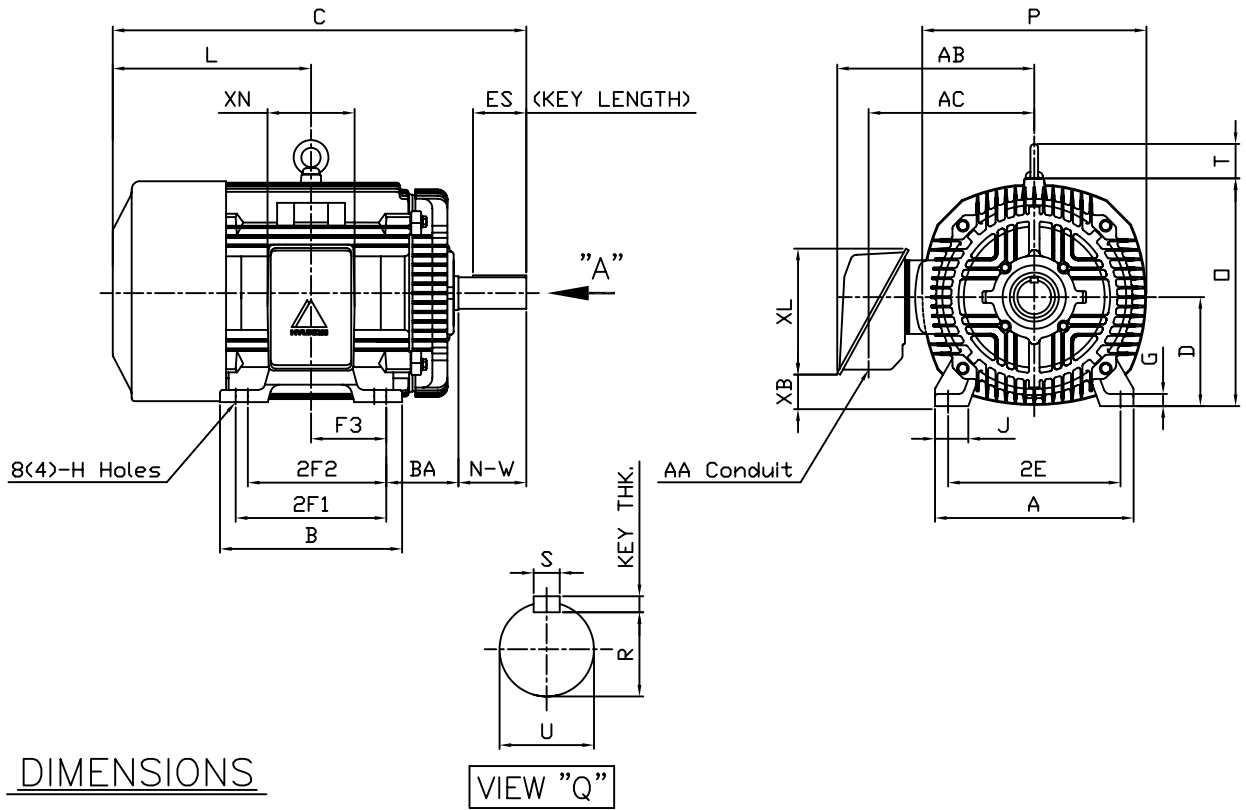

DIMENSIONS

VIEW "Q"

M O U N T I N G									C O N D U I T B O X					APPROX. WGT.(LB)	
A	B	2E	2F1	2F2	F3	G	J	H	AA	AB	AC	XB	XL	XN	
16.14	14.92	14.00	(12.25)	11.25	6.122	0.98	2.72	0.66	3.00	17.13	13.82	2.70	10.24	7.09	780

O V E R A L L							S H A F T			KEY	BEARING			
BA	C	D	L	O	P	T	U	N-W	KEYWAY			THK.	DRIVE END	OPP. DRIVE END
									R	ES	S			
5.88	35.20	9.00	17.32	18.50	18.23	2.80	2.375	5.88	2.021	4.28	0.625	0.625	6314C3	6213C3

NOTE

1. Dimension "D" tolerance : +0.00inch - 0.03inch (143T-365T) ; +0.000inch - 0.06inch (404T-449T)
2. Dimension "U" tolerance : +0.000inch - 0.005inch (143T-215T), +0.000inch - 0.001inch (254T-449T)
3. Dimension "R" tolerance : +0.000inch - 0.015inch

Q'TY	DESCRIPTION	MATERIAL	DIMENSION	WEIGHT	PART NO.	REMARK	NO.
APPD BY	K.J.KANG	UNIT	INCH	SUBJECT	364T	CAD PROJ ㄹ \ FILE ㄹ	
Q.P CHK	O.J.KIM	SCALE	N/S				
CHKD BY	N.D.LEE	PROJEC'N	3 각법(3rd Angle)	TITLE OUTLINE			
DSND BY	A.L.SHIN	DATE	2011.03.31				
				REF. NO	A8113AA	Sheet No.	of
				DWG NO	350A8113AA	Revision No.	0



PERFORMANCE CURVE

CURVE NO.

P-PLP364SR04

Type	:	PLP
Full Load Torque	:	178.1 lb.ft
Motor moment of Inertia (J)	:	17.640 lb.ft ²
Load moment of Inertia (J)	:	616.991 lb.ft ²

45 kW	60 HP	60 Hz	
4 P	Rated Speed	: 1780 RPM	
Rated Voltage	575V	460V	230V
Full Load Current	56.0A	69.9A	139.9A

SPEED VS TORQUE & CURRENT CURVE

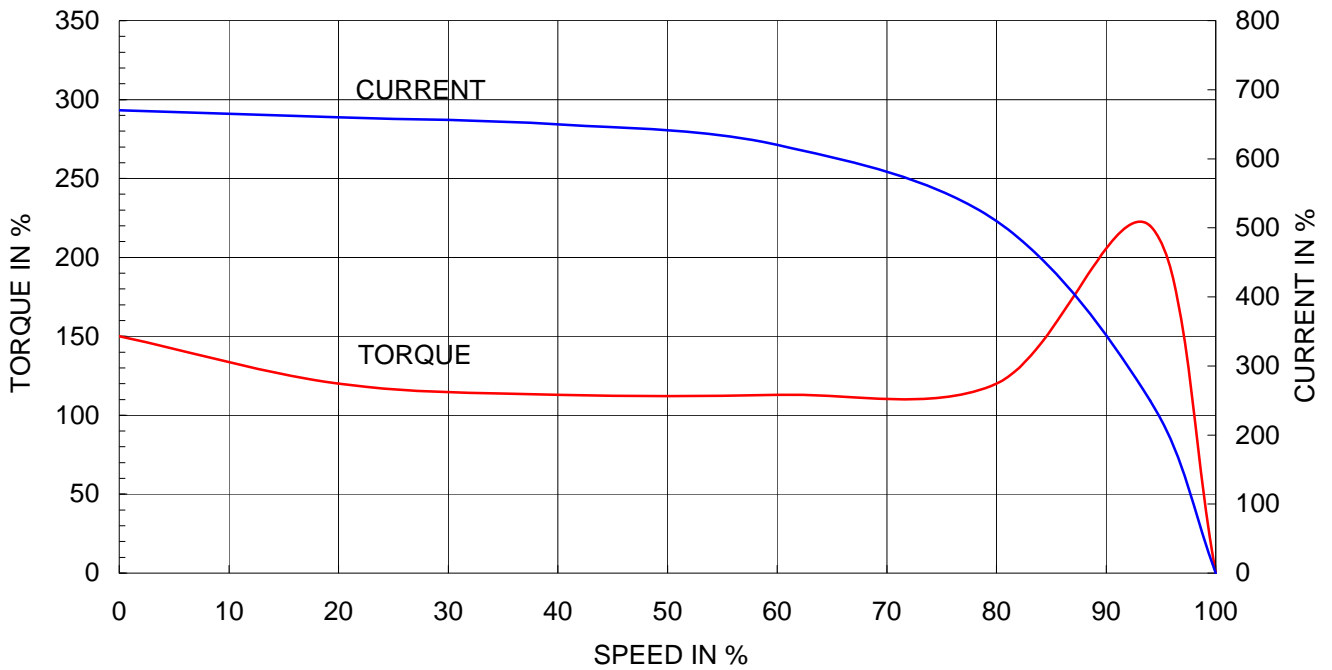

OUTPUT VS EFF., P.F & CURRENT CURVE

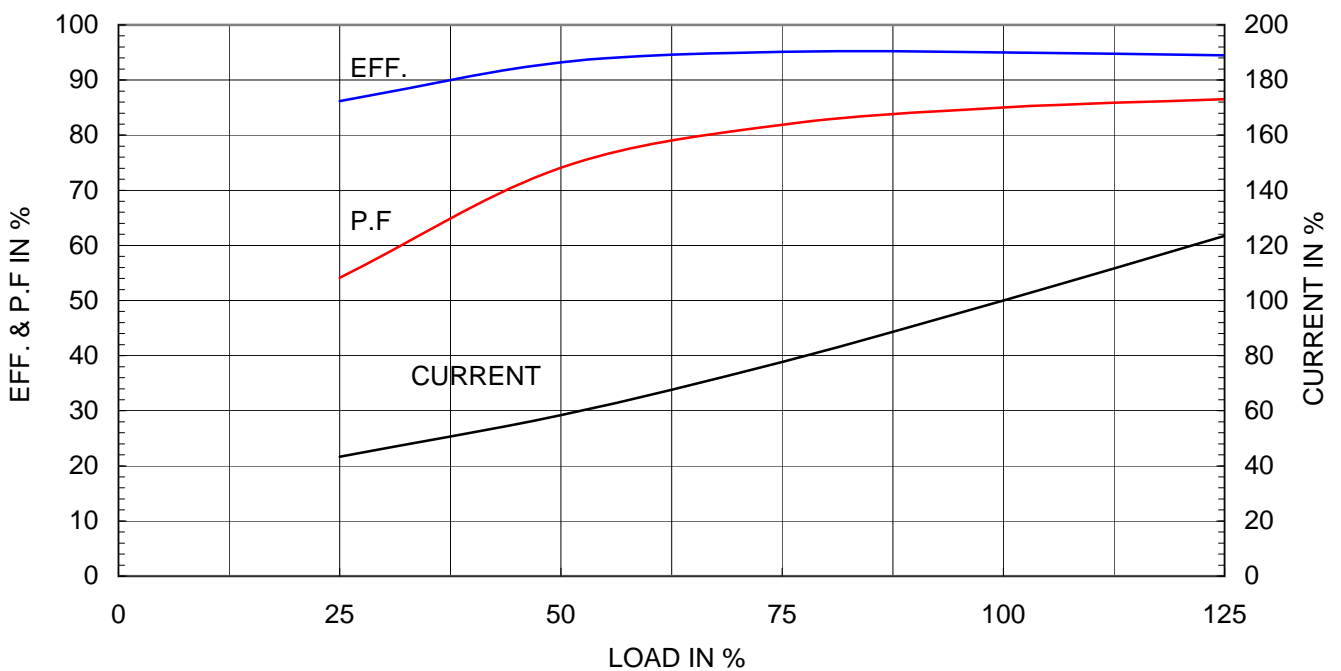



THERMAL LIMIT & TIME CURRENT CURVE

CURVE NO.

T-PLP60-18-364T

Type :	PLP60-18-364T		60	HP	4	P	60	Hz
FULL LOAD TORQUE :	178.1	lb.ft	RATED SPEED :		1780 rpm			
J OF LOAD :	-	lb.ft ²	VOLTAGE		460 V	575 V		
J OF MOTOR :	17.6	lb.ft ²	RATED CURRENT		69.9A	56.0A		

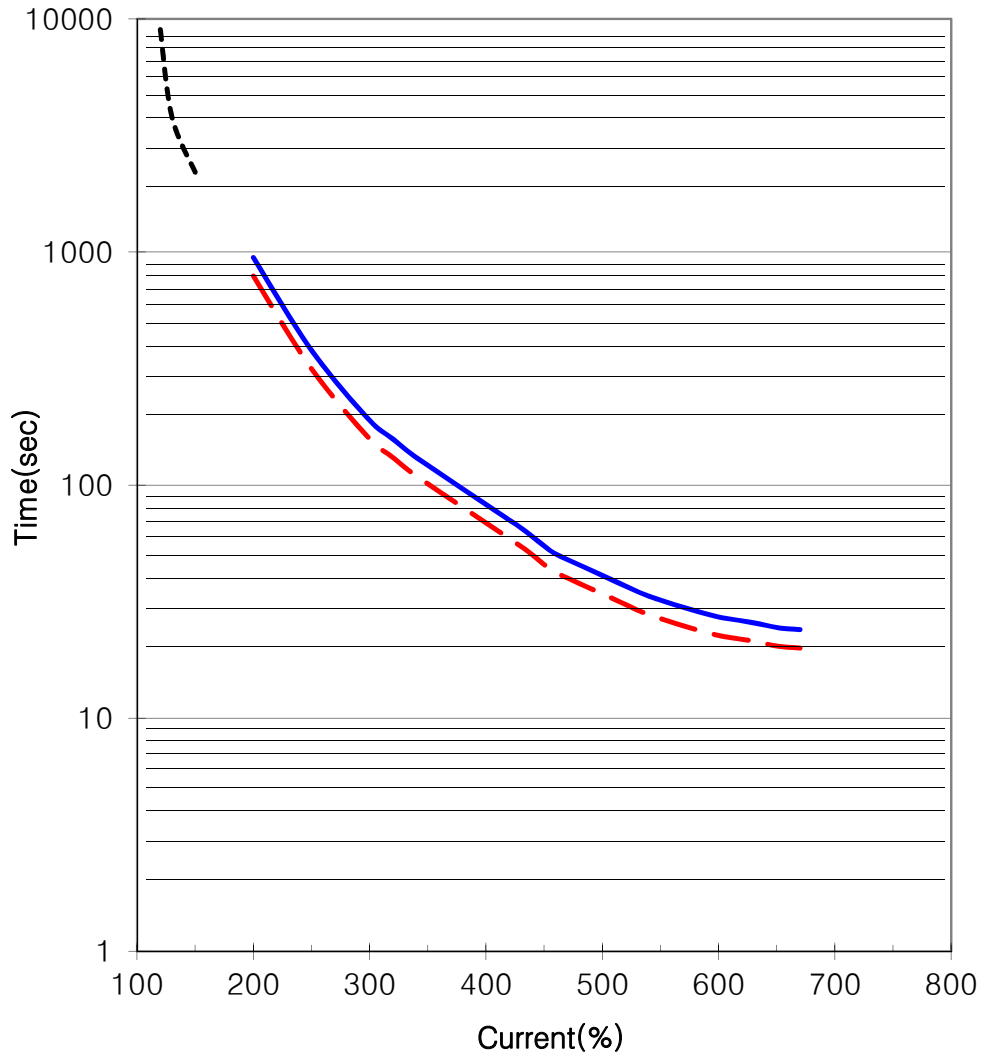

— THERMAL LIMIT CURVE AT COLD CONDITION
- - THERMAL LIMIT CURVE AT HOT CONDITION

STARTING TIME	SAFE STALL TIME
- at rated voltage starting	20 sec. at Hot condition
- at 80% of rated voltage starting	24 sec. at Cold condition

THIS DRAWING IS PROPRIETARY TO HHI. NO PART OF THIS DRAWING MAYBE REPRODUCED WITHOUT THE PERMISSION OF HHI.

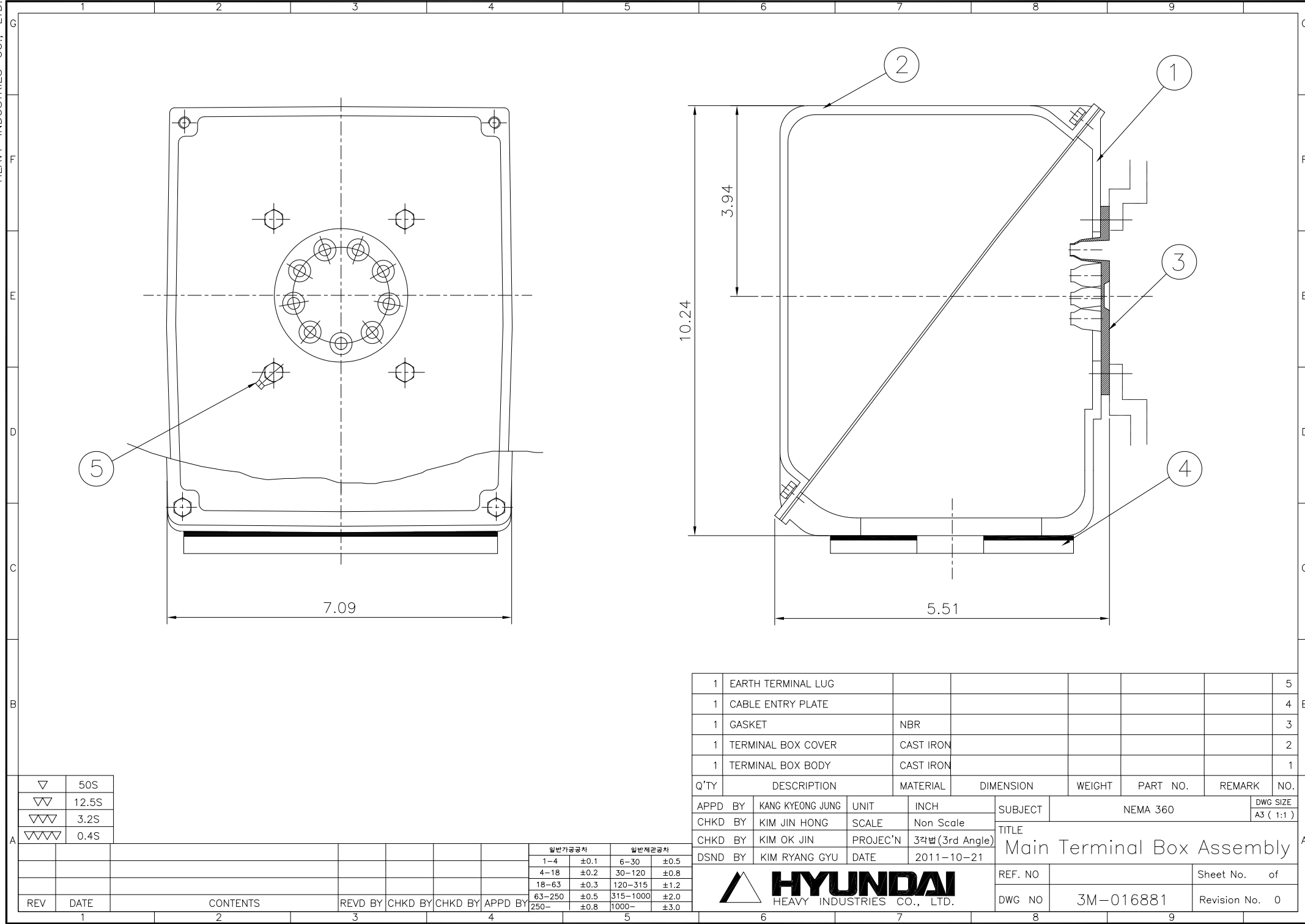

▽	50S
▽▽	12.5S
▽▽▽	3.2S
▽▽▽▽	0.4S

REV	DATE	CONTENTS	REVD BY	CHKD BY	CHKD BY	APPD BY
1						

일반기준공차		일반재관공차	
1-4	±0.1	6-30	±0.5
4-18	±0.2	30-120	±0.8
18-63	±0.3	120-315	±1.2
63-250	±0.5	315-1000	±2.0
250-	±0.8	1000-	±3.0

Q'TY	DESCRIPTION	MATERIAL	DIMENSION	WEIGHT	PART NO.	REMARK	NO.
1	EARTH TERMINAL LUG						5
1	CABLE ENTRY PLATE						4
1	GASKET	NBR					3
1	TERMINAL BOX COVER	CAST IRON					2
1	TERMINAL BOX BODY	CAST IRON					1

APPD BY	KANG KYEONG JUNG	UNIT	INCH	SUBJECT	NEMA 360	DWG SIZE	A3 (1:1)
CHKD BY	KIM JIN HONG	SCALE	Non Scale	TITLE			
CHKD BY	KIM OK JIN	PROJEC'N	3각법 (3rd Angle)	Main Terminal Box Assembly			
DSND BY	KIM RYANG GYU	DATE	2011-10-21				

REF. NO		Sheet No.	of
DWG NO	3M-016881	Revision No.	0