

MODEL NUMBER	IEEE250-36-449TS		
HORSEPOWER	250		
RPM / POLES	3600 / 2		
VOLTAGE / PHASE	460 / 3		
FRAME	449TS		
ENCLOSURE / DEGREE OF PROTECTION	TEFC / IP56		
FREQUENCY	60 HZ		
FULL LOAD SPEED	3570 RPM		
SERVICE FACTOR	1.15		
INSULATION CLASS	F Class N Varnish		
FULL LOAD AMPS; 460	276.6 A		
LOCKED ROTOR CURRENT (% Full Load)	700 %		
NEMA CODE LETTER	G		
EFFICIENCY / POWER FACTOR	<u>LOAD</u>	<u>EFF.</u>	<u>P.F.</u>
	100 %	95.8 %	90.0 %
	75 %	95.8 %	89.0 %
	50 %	94.3 %	87.0 %
DUTY CYCLE	S1 / Continuous		
TORQUE	<u>FULL LOAD</u>	<u>LRT</u>	<u>BDT</u>
	375.0 lb.ft	120 %	220 %
NEMA DESIGN	B		
MOMENT OF INERTIA	<u>LOAD (Max.)</u>	<u>MOTOR</u>	
	463.931 lb.ft <sup>2</sup>	58.330 lb.ft <sup>2</sup>	
SOUND PRESSURE LEVEL ( No Load 1 M From Motor)	82 dB(A)		
MAX. SHAFT VIBRATION	0.08 In/Sec – Peak Velocity		
NUMBER OF STARTS (Hot / Cold)	2 Hot / 3 Cold		
MAX. AMBIENT TEMPERATURE	40° C		
MAX. ELEVATION	3300 Ft. Above Sea Level		
TEMPERATURE RISE (At Full Load)	80° C		
DRIVE-END BEARING	6314C3		
OPPOSITE DRIVE-END BEARING	6314C3		
BEARING SEAL TYPE	ProTech™ IP66 Labyrinth On DE and ODE		
GREASE TYPE	Mobil Polyrex EM		
MOUNTING	F1 (F2 Suitable), W6, W8, B3, V5, V6		
ROTATION	Uni-Directional, CCW		
APPROXIMATE WEIGHT	2430 lbs		
AREA CLASSIFICATION	Class I, Division 2, Groups A, B, C, D, T3A		
PAINT	Epoxy		
INVERTER RATING	10:1 CT / 1000:1 VT		
INSULATION TYPE	Hyundai Inverter Shield, Meets NEMA MG1 Part 31		
SPECIFICATION - In Accordance With	IEEE-841, Version 2009, NEMA, CSA		



CC 038A







# PERFORMANCE CURVE

CURVE NO.

**P-PLP449SR02**

Type	:	PLP
Full Load Torque	:	375.0 lb.ft
Motor moment of Inertia (J)	:	58.330 lb.ft <sup>2</sup>
Load moment of Inertia (J)	:	463.931 lb.ft <sup>2</sup>

190 kW	250 HP	60 Hz	
2 P	Rated Speed	: 3570 RPM	
Rated Voltage	575V	460V	230V
Full Load Current	221.3A	276.6A	553.2A

SPEED VS TORQUE & CURRENT CURVE

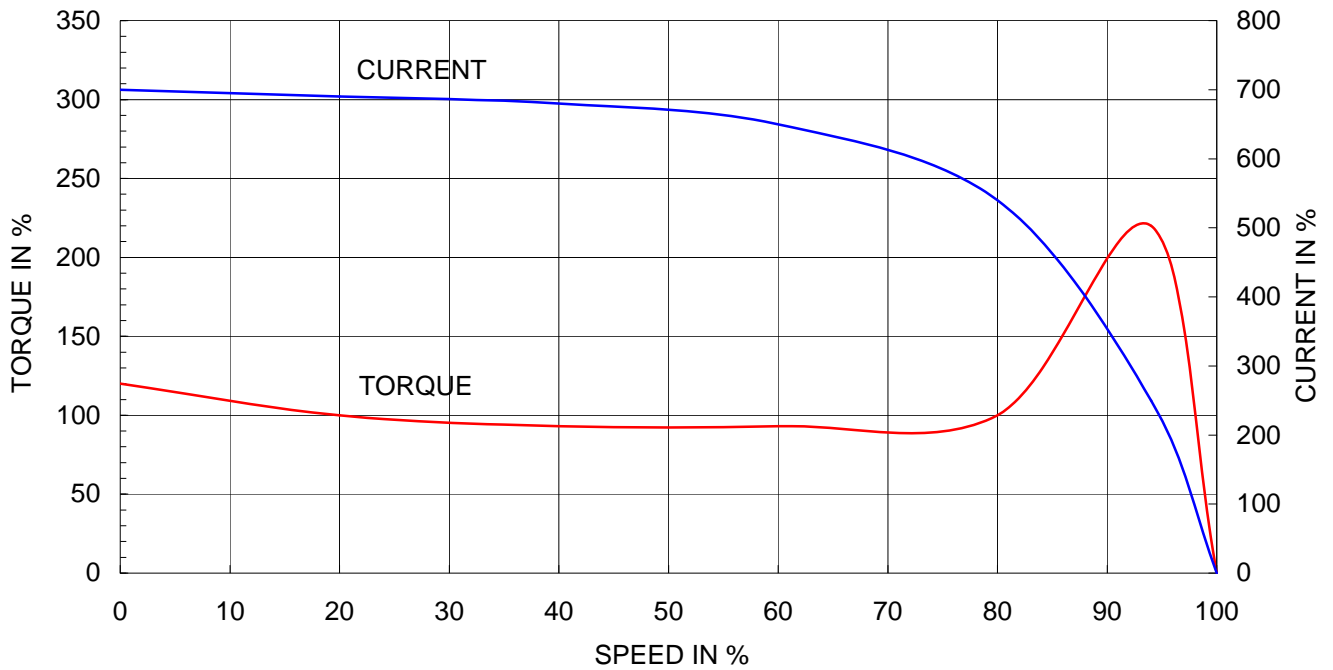

OUTPUT VS EFF., P.F & CURRENT CURVE

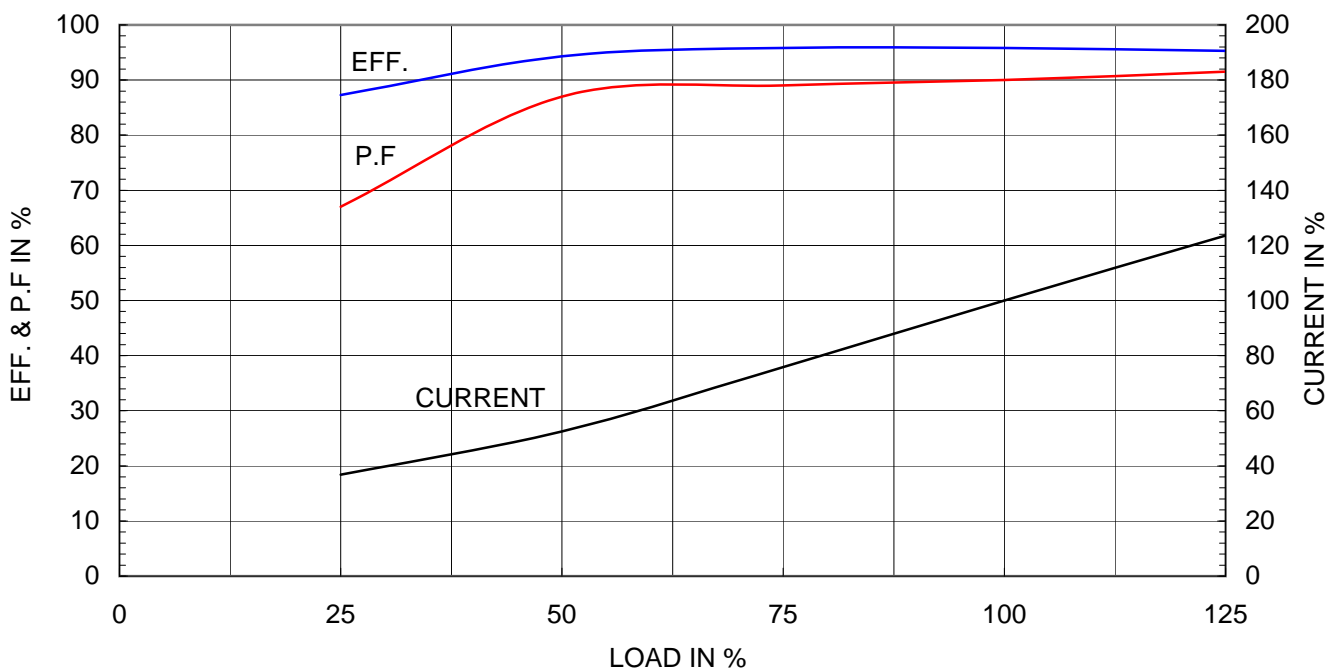



# THERMAL LIMIT & TIME CURRENT CURVE

CURVE NO.

T-PLP250-36-449TS

Type :	PLP250-36-449TS	250	HP	2	P	60	Hz
FULL LOAD TORQUE :	375.0	lb.ft	RATED SPEED :		3570 rpm		
J OF LOAD :	-	lb.ft <sup>2</sup>	VOLTAGE		460 V	575 V	
J OF MOTOR :	58.3	lb.ft <sup>2</sup>	RATED CURRENT		276.6A	221.3A	

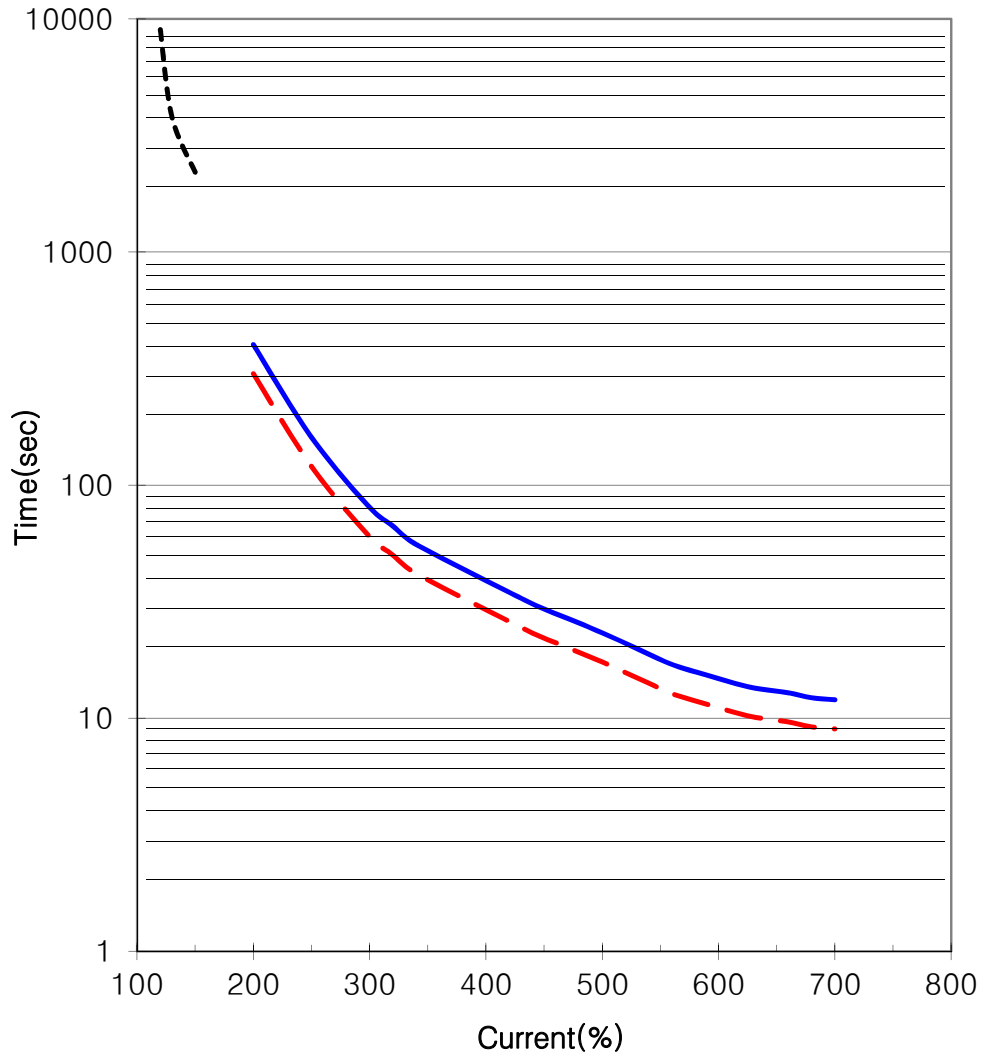

— THERMAL LIMIT CURVE AT COLD CONDITION  
- - THERMAL LIMIT CURVE AT HOT CONDITION

STARTING TIME	SAFE STALL TIME
- at rated voltage starting	9 sec. at Hot condition
- at 80% of rated voltage starting	12 sec. at Cold condition

THIS DRAWING IS PROPRIETARY TO HEECO. NO PART OF THIS DRAWING MAYBE REPRODUCED WITHOUT THE PERMISSION OF HHI.

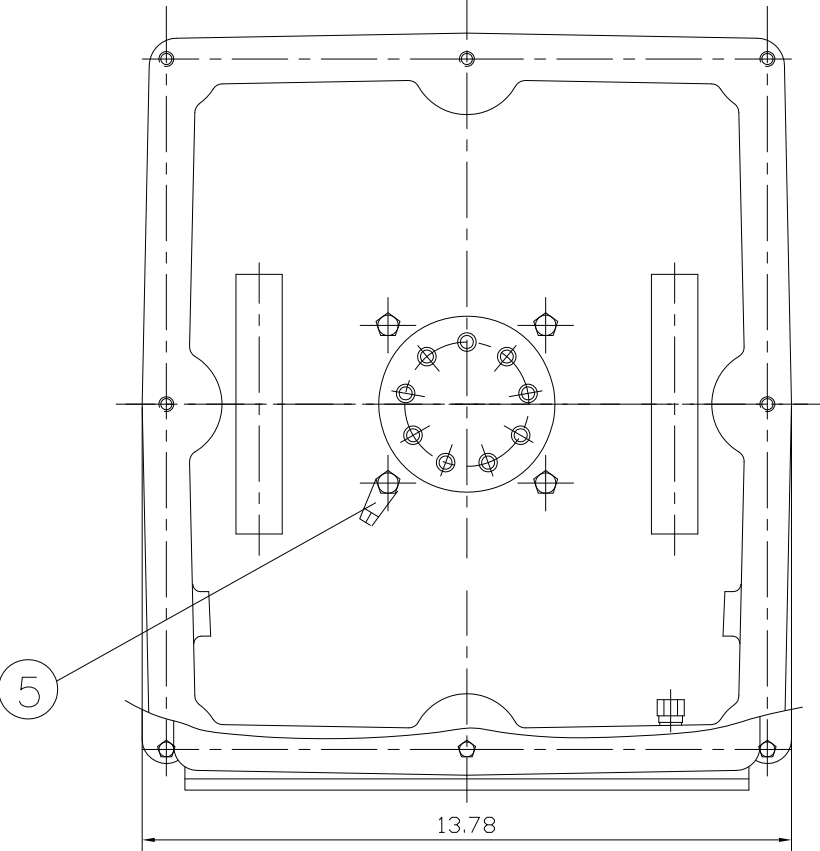
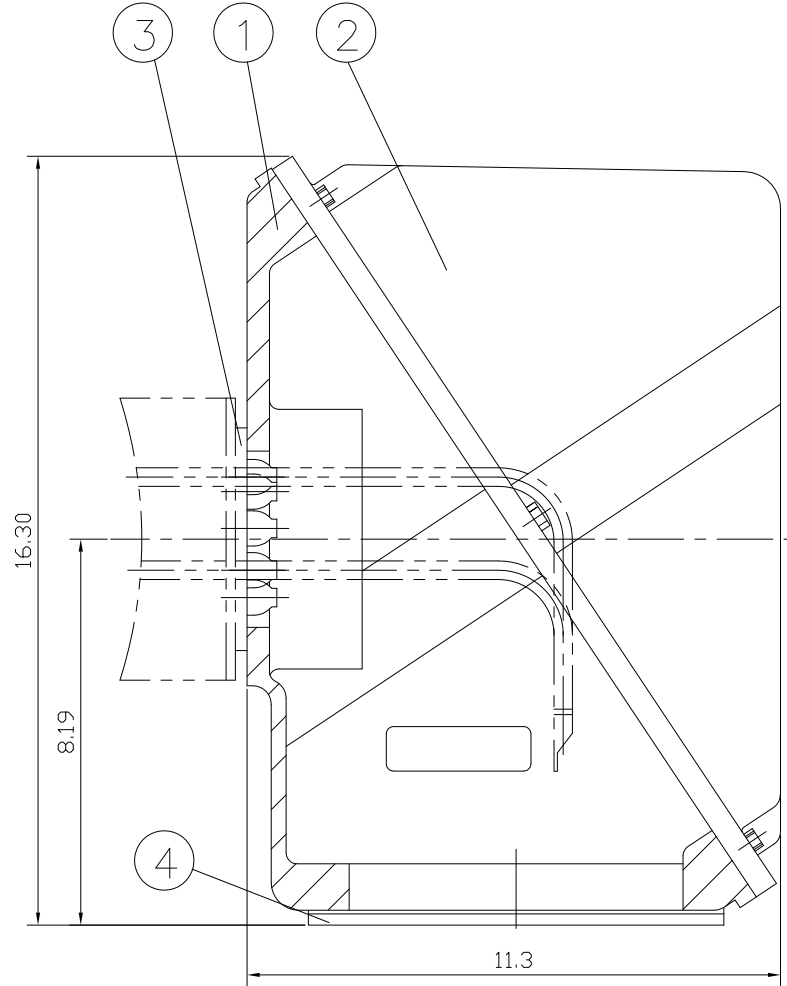

REV	DATE	CONTENTS	REVD BY	CHKD BY	CHKD BY	APPD BY
1						

일반가공공차		일반재관공차	
1-4	±0.1	6-30	±0.5
4-18	±0.2	30-120	±0.8
18-63	±0.3	120-315	±1.2
63-250	±0.5	315-1000	±2.0
250-	±0.8	1000-	±3.0

1	EARTH TERMINAL LUG						5
1	CABLE ENTRY PLATE						4
1	GASKET	NBR					3
1	TERMINAL BOX COVER	CAST IRON					2
1	TERMINAL BOX BODY	CAST IRON					1
Q'TY	DESCRIPTION	MATERIAL	DIMENSION	WEIGHT	PART NO.	REMARK	NO.

APPD BY	KANG KYOUNG JUNG	UNIT	INCH	SUBJECT	NEMA 440	CAD PROJ \ FILE
CHKD BY	KIM OK JIN	SCALE	1/3	S/T-BOX-M/3r038513		
DSND BY		PROJEC'N	3rd Angle	TITLE		
TRCD BY	KIM JONG SEON	DATE	99.04.28	Main Terminal Box Assembly		



REF. NO		Sheet No.	of
DWG NO	3M-038513	Revision No.	0