

MODEL NUMBER	HHI40-18-575-324T		
HORSEPOWER	40		
RPM / POLES	1800 / 4		
VOLTAGE / PHASE	575 V / 3		
FRAME	324T		
ENCLOSURE / DEGREE OF PROTECTION	TEFC / IP55		
FREQUENCY	60 HZ		
FULL LOAD SPEED	1780 RPM		
SERVICE FACTOR	1.15 SF at 40° C / 1.0 SF at 65° C		
INSULATION CLASS	F Class N Varnish		
FULL LOAD AMPS; 575	39.0 A		
LOCKED ROTOR CURRENT (% Full Load)	700 %		
NEMA CODE LETTER	H		
EFFICIENCY / POWER FACTOR	<u>LOAD</u>	<u>EFF.</u>	<u>P.F.</u>
	100 %	94.1 %	82.0 %
	75 %	94.1 %	79.0 %
	50 %	93.1 %	73.5 %
DUTY CYCLE	S1 / Continuous		
TORQUE	<u>FULL LOAD</u>	<u>LRT</u>	<u>BDT</u>
	118.7 lb.ft.	160 %	220 %
NEMA DESIGN	B		
MOMENT OF INERTIA	<u>LOAD (Max.)</u>	<u>MOTOR</u>	
	409.301 lb.ft. <sup>2</sup>	7.121 lb.ft. <sup>2</sup>	
SOUND PRESSURE LEVEL ( No Load 1 M From Motor)	77 dB(A)		
NUMBER OF STARTS (Hot / Cold)	2 Hot / 3 Cold		
MAX. AMBIENT TEMPERATURE	40° C at 1.15 SF / 65° C at 1.0 SF		
MAX. ELEVATION	3300 Ft. Above Sea Level		
TEMPERATURE RISE (At Full Load)	80° C		
DRIVE-END BEARING	6313ZC3		
OPPOSITE DRIVE-END BEARING	6211ZC3		
GREASE TYPE	Mobil Polyrex EM		
MOUNTING	F1 (F2 Suitable), W6, W8, B3, V5, V6		
ROTATION	Bi-Directional		
APPROXIMATE WEIGHT	626 lbs.		
AREA CLASSIFICATION	Class I, Division 2, Groups A, B, C, D		
INVERTER RATING	10:1 CT / 20:1 VT - Meets NEMA MG1 Part 31		
SPECIFICATION - In Accordance With	NEMA, CSA		



CC 038A





# TEFC

**THREE PHASE INDUCTION MOTOR**

**TYPE**

LP, JP  
CAST IRON FRAME

FRAME SIZE	OUTPUT(HP)	POLES	Hz	TIME RATING

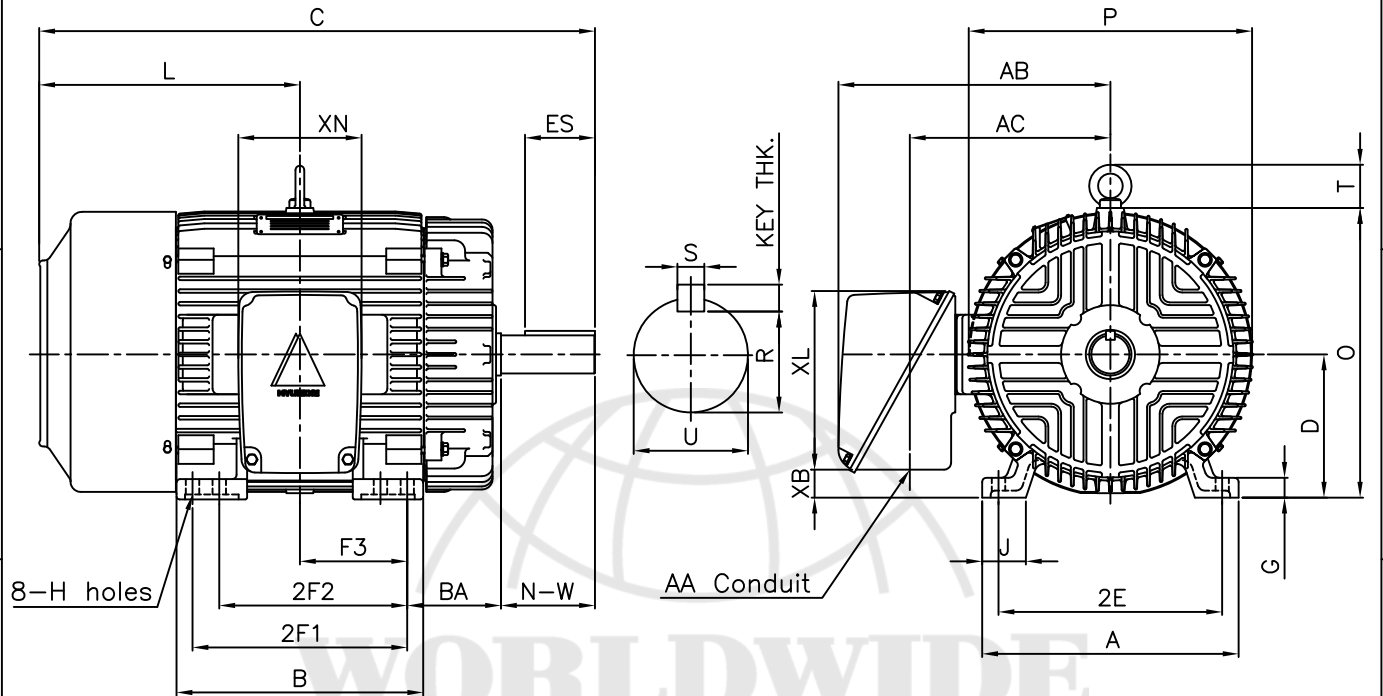

## DIMENSIONS

M O U N T I N G									C O N D U I T B O X						APPROX. WGT.(LB)	
A	B	2E	2F1 <sup>5)</sup>	2F2 <sup>4)</sup>	F3	G	J	H	AA	AB	AC	XB	XL	XN	324T	326T
14.33	13.78	12.50	12.00	10.50	6.00	1.11	2.36	0.66	2.00	15.20	11.21	1.57	10.16	7.01	550	560

O V E R A L L							S H A F T					KEY THK.	B E A R I N G	
BA	C	D	L	O	P	T	U	N-W	KEYWAY				DRIVE END	OPP. DRIVE END
									R	ES	S			
5.25	31.07	8.00	14.57	16.19	15.84	2.41	2.125	5.25	1.845	3.91	0.500	0.500	6313ZC3	6211ZC3

### NOTE

- 1.Dimension "D" tolerance : +0.00inch - 0.03inch
- 2.Dimension "U" tolerance : +0.000inch - 0.001inch
- 3.Dimension "R" tolerance : +0.000inch - 0.015inch
- 4.Location of holes for 324T frame
- 5.Location of holes for 326T frame

APPD BY	KIM.Y.S	UNIT	INCH	SUBJECT	NEMA 324T/326T	CAD PROJ \ FILE	
CHKD BY	KO.S.H	SCALE	1/12			XSMOUTN\A1112AA	
CHKD BY		PROJEC'N	3rd Angle	TITLE <b>OUTLINE</b>			
DSND BY	LEE KWANG SOO	DATE	2004.04.02				
				REF. NO	A1112AA	Sheet No. of	
				DWG NO	350A1112AA	Revision No. 0	

Type	: PLP
Full Load Torque	: 118.7 lb.ft
Motor moment of Inertia (J)	: 7.121 lb.ft <sup>2</sup>
Load moment of Inertia (J)	: 409.301 lb.ft <sup>2</sup>

30 kW	40 HP	60 Hz	
4 P	Rated Speed	: 1780 RPM	
Rated Voltage	575V	460V	230V
Full Load Current	39.0A	48.8A	97.6A

SPEED VS TORQUE & CURRENT CURVE

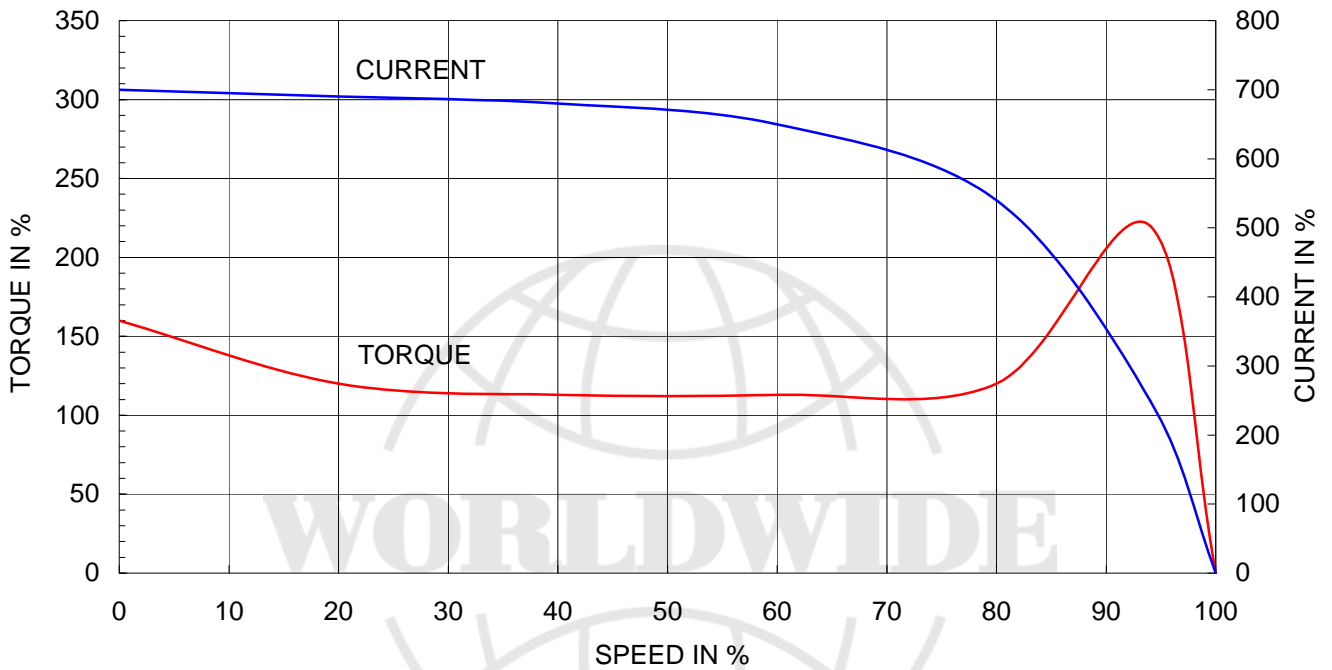

OUTPUT VS EFF., P.F & CURRENT CURVE

