

WDC CONTROL SERIES

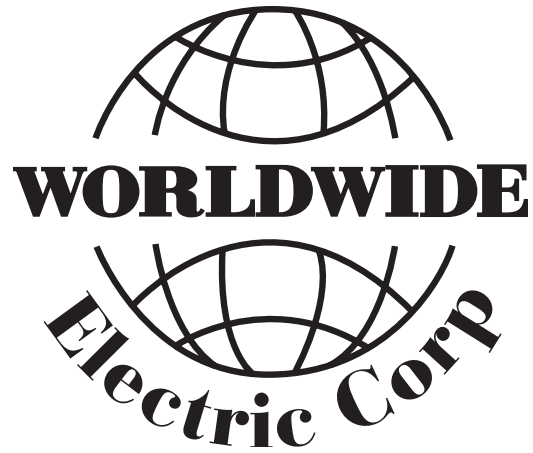

Instruction Manual

Variable Speed DC Control



P.O. Box 307
1 Grove Street - Suite 201B
Pittsford, NY 14534

Phone: (800) 808-2131
Fax: (800) 711-1616
www.worldwideelectric.net

TABLE OF CONTENTS

WARRANTY	1
INTRODUCTION	2
CONTROL FEATURES	2
HEATSINK DIMENSIONS	2
ENCLOSED MODEL HOOK-UP DIAGRAM	3
WIRING PROCEDURE & FUSING	4
TERMINAL STRIP WIRING	4
START-UP PROCEDURE & ADJUSTMENTS	5
TRIMPOT ADJUSTMENT PROCEDURE & SETTING CHART	6
DC CONTROL WITH REVERSING	7
CONTROL MODIFICATIONS	7
IN CASE OF DIFFICULTY	8
SPECIFICATIONS & TYPICAL MOTOR CURRENTS	9
WDC SERIES PARTS PLACEMENT & LIST	9
WDC SERIES SCHEMATIC	10

WARRANTY

WorldWide Electric Corporation (WWE) warrants its products to be free from defects in material and workmanship. The exclusive remedy for this warranty is WWE factory replacement of any part or parts of such product which shall within 12 months after delivery to the purchaser be returned to WWE factory with all transportation charges prepaid and which WWE determines to its satisfaction to be defective. This warranty shall not extend to defects in assembly by other than WWE or to any article which has been repaired or altered by other than WWE or to any article which WWE determines has been subjected to improper use. WWE assumes no responsibility for the design characteristics of any unit or its operation in any circuit or assembly. This warranty is in lieu of all other warranties, express or implied; all other liabilities or obligations on the part of WWE, including consequential damages, are hereby expressly excluded.

NOTE: Carefully check the control for shipping damage. Report any damage to the carrier immediately. Do not attempt to operate the drive if visible damage is evident to either the circuit or to the electronic components.

All information contained in this manual is intended to be correct, however information and data in this manual are subject to change without notice. WWE makes no warranty of any kind with regard to this information or data. Further, WWE is not responsible for any omissions or errors or consequential damage caused by the user of the product. WWE reserves the right to make manufacturing changes which may not be included in this manual.

WARNING

Improper installation or operation of this control may cause injury to personnel or control failure. The control must be installed in accordance with local, state, and national safety codes. Make certain that the power supply is disconnected before attempting to service or remove any components!!! If the power disconnect point is out of sight, lock it in disconnected position and tag to prevent unexpected application of power. Only a qualified electrician or service personnel should perform any electrical troubleshooting or maintenance. At no time should circuit continuity be checked by shorting terminals with a screwdriver or other metal device.

INTRODUCTION

- The WDC Series variable speed DC motor control is a versatile, general purpose control rated to 2 HP.
- The control has a dual voltage input (may accommodate either 120 or 240 VAC). It is available with an adjustable HP range of 1/8 thru 1 HP for 120 VAC, and 1/4 thru 2 HP for 240 VAC input.
- Designed for DC Permanent Magnet, Shunt Wound, and some Universal (AC/DC) motors in the above horsepower ranges.
- Incoming AC voltage is also converted to adjustable full wave rectified DC voltage (via a packaged bridge) to operate the DC motor. Also, a full wave field voltage is provided for shunt wound motors (see page 4 for voltages).
- The control incorporates transient voltage protection with adjustable current limit and an AC fuse for protection. It features adjustable minimum and maximum speeds along with adjustable acceleration and IR Compensation. Tach feedback is accomplished thru a connection to a pin (P2) on the printed circuit board.
- The WDC Series has a linear acceleration/deceleration ramp.
- The control also has a barrier type terminal strip for all power and control wiring.
- The enclosed model uses a gasketed cover assembly that is rated NEMA 4/12.
- cULus Listed.

CONTROL FEATURES

MIN. SPEED (minimum speed) - Allows adjustment of the motor speed when the speedpot is set at minimum (CCW). This permits the user to eliminate the "deadband" on the main speed control permitting zero calibration. Clockwise rotation of "MIN" trimpot increases minimum motor speed.

MAX. SPEED (maximum speed) - provides for adjustment of the motor speed when the speedpot is set at maximum (CW). This permits the user to eliminate the top end "deadband", which will provide full speed at maximum rotation. Rotation of the "MAX" trimpot in the clockwise direction increases the maximum motor speed.

ACCEL (acceleration) - allows adjustment of the motor acceleration from a minimum of 0.5 seconds to approximately 8.0 seconds. The deceleration time depends on the ACCEL setting.

I. R. COMP (speed regulation) - adjusts the control output to compensate for speed changes caused by varying motor loads. As the motor load is increased, I.R. COMP increases the voltage output of the control. Clockwise rotation of the "I.R. COMP" trimpot will increase compensation.

CUR. LIM. (current limit) - provides protection from excessive armature current by limiting the maximum armature current the control can provide. This enables adjustment of the maximum torque the motor can deliver. Current limit adjustment (CUR LIM) is set at 125% of the rated motor current (torque) based on horsepower. Clockwise rotation of the "CUR LIM" trimpot increases the current (torque) the control will provide.

INHIBIT TERMINAL PIN (P2) - allows the user a choice of stopping and starting hard (fast) or stopping hard with a soft start through an adjustable acceleration ramp, without breaking the AC lines (see page 6).

TERMINAL STRIP - allows for connection of AC lines, motor leads, motor field (if needed), and speed potentiometer.

HEATSINK DIMENSIONS

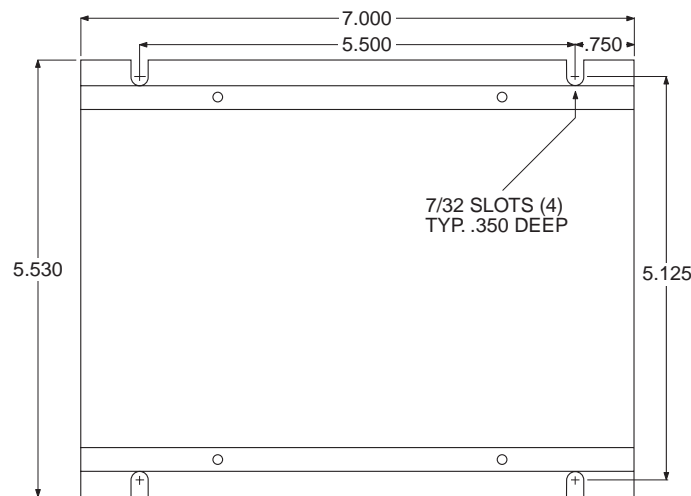

Allow 3.50" for height clearance, 7.40" for overall length.

WDC SERIES ENCLOSED HOOK-UP DIAGRAM

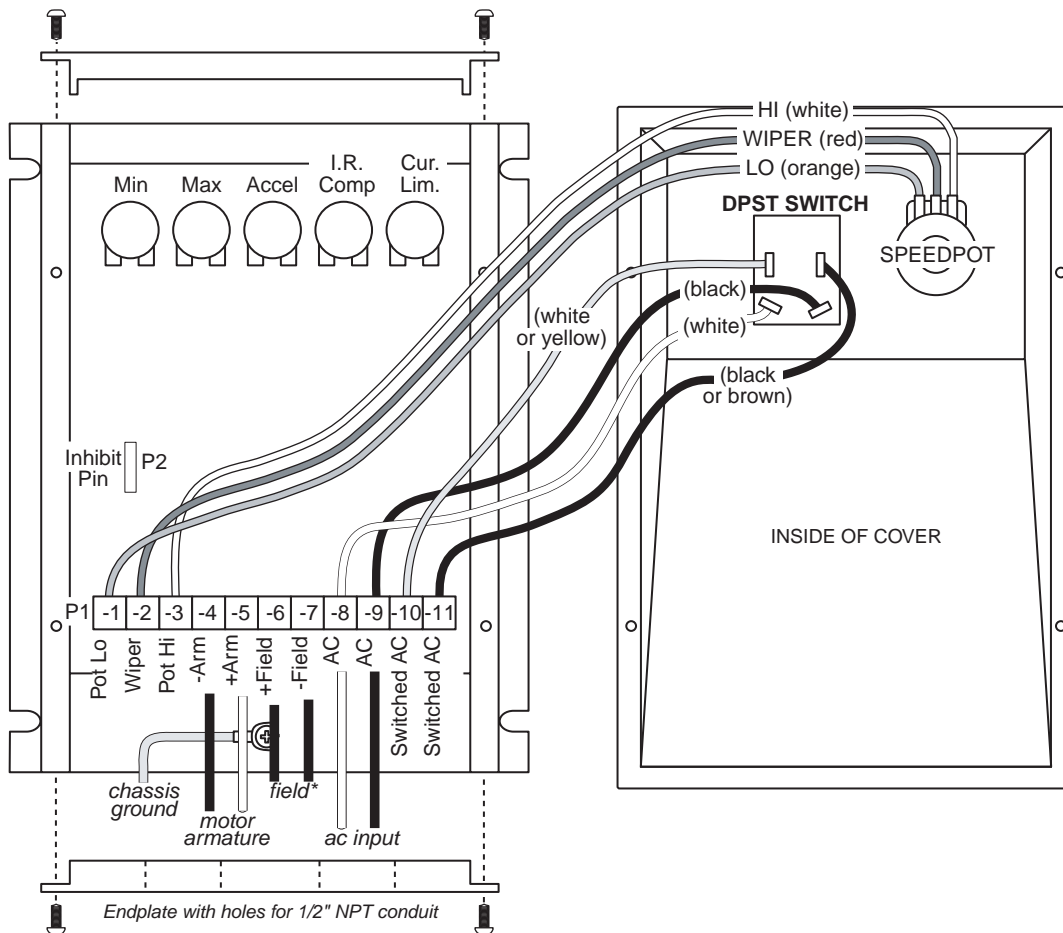

* Used for shunt wound motors only! No connection is made to these terminals when using permanent magnet motors.

WARNING

1. Be sure the control housing is properly grounded.
2. Arm connections must not be switched or broken while the control is on. Serious damage may result.
3. For non-speedpot applications, the input connections to the Lo-Wiper-Hi leads must not be grounded. Serious control damage may result from a grounded input.

WIRING PROCEDURE

1. Size all wires which carry armature or line current to handle currents as specified by national, state, and/or local codes. All other wires may be #18 AWG or smaller as permitted by local code.
2. Separate control wires from all the Armature and AC line wires when routed in conduits or in wire trays. The enclosed version has two threaded holes (1/2" NPT) in one endplate, located near the terminal strip, for this purpose.

FUSING

The control is provided with a fuse in AC line 1 (P1-11). This fuse is sized to open in the event of a shorted armature or if an armature line is shorted to earth ground. As long as 120 VAC input is connected properly, there is no additional fusing needed.

For 240 VAC applications, an external fuse may be used in AC line 2 (P1-10). This fuse should be a Bussman ABC10 or Little-Fuse 314-010. This added fuse will provide protection on both AC legs to the control. If you desire not to fuse both legs, the fuse in the control will open in the event of excessive armature currents.

Note: AC current is determined by motor characteristics. In some applications it may be necessary to increase fuse value.

TERMINAL STRIP WIRING

The WDC Series has an 11 position terminal strip for ease of connection.

- P1-1 (SPEEDPOT LO) Connects to low side (orange wire) of the 5K speedpot (normally the CCW end). This input is raised and lowered by the MIN. trimpot.
- P1-2 (SPEEDPOT WIPER) Connects to wiper (red wire) of the 5K speedpot (center lead).
- P1-3 (SPEEDPOT HI) Connects to high side (white wire) of the 5K speedpot (CW end). This is internal +12 volts. For start-stop applications, the connection between this terminal and Inhibit (P2) can be opened and closed by a SPST switch. NOTE: INPUT MUST NOT BE GROUNDED!!
- P1-4 (-ARM) Connects to minus (-) Armature wire (A2) on motor.
- P1-5 (+ARM) Connects to plus (+) Armature wire (A1) on motor. 0-90 VDC for 120 VAC input OR 0-180 VDC for 240 VAC input. See "SPECIFICATIONS" for output rating.
- P1-6 (+FIELD) DO NOT USE for permanent magnet motor. This supplies +Field voltage for a SHUNT WOUND MOTOR. Refer to Field Voltage table. For motors with dual voltage field (i.e. 50/100V or 100/200V), make sure highest value is connected.

FIELD VOLTAGE TABLE		
VAC INPUT	120	240
VDC FIELD	100	200

- P1-7 (-FIELD) Connect minus (-) Field wire of SHUNT WOUND MOTOR.
- P1-8 } VERY IMPORTANT !!! Refer to "CUSTOMER FUSING", shown above.
- P1-9 } (AC) 120VAC - Connect incoming hot AC (black wire) to P1-9 and Neutral (white wire) to P1-8.
Connect ground (green wire) to Chassis Ground, as shown in diagram - page 3.
240VAC - Connect both hot sides, one to P1-8 and one to P1-9. Also connect ground wire to Chassis Ground.
- P1-10 } VERY IMPORTANT !!! Refer to "CUSTOMER FUSING", shown above.
- P1-11 } (SWITCHED AC) No connections to P1-10 and P1-11. This is for switched AC output. Note "FACTORY WIRING" (page 3). Pilot lights can be connected between these terminals. The voltage present at these terminals is AC input voltage.

WARNING: Do not attempt to perform a Hi-Pot test across AC lines with control in circuit.
This will result in immediate or long term damage to the control.

START-UP PROCEDURE

WARNING: ALL POWER MUST BE TURNED OFF BEFORE PROCEEDING !!!

1. Recheck all wiring. Accidental grounds, loose or pinched wires on armature or speedpot wires may damage the control when power is applied.
2. Check to see that incoming service is of correct voltage.
3. Turn speedpot to zero (fully CCW).
4. Turn power on and advance speedpot while observing motor.
WARNING: POWER MUST BE OFF BEFORE STEP 5 CAN BE ACCOMPLISHED!
5. If motor rotation is incorrect, turn power off at external disconnect and reverse +ARM and -ARM connections.
6. Check for satisfactory operation throughout the speed range.
7. If operation is satisfactory, no readjustments are needed.
8. If instability or surging is observed, or maximum speed is higher than desired, see section "TRIMPOT ADJUSTMENT".
9. For other problems, consult section "IN CASE OF DIFFICULTY".

ADJUSTMENTS

The trimpot adjustments, MIN, MAX, I.R. COMP, and CUR LIM are checked at the factory using a typical motor at 240 VAC input. Use the following TRIMPOT ADJUSTMENT PROCEDURE to set up the drive for your application.

The trimpot chart is approximate. The chart is valid when using the speedpot or a 0-10/12 VDC input signal to set speed.

These adjustments are permanent; periodic readjustment is normally not needed. Operation of the control beyond $\pm 10\%$ of normal line voltage could result in readjustments.

TRIMPOT ADJUSTMENT PROCEDURE

TRMPOT	FUNCTION	ADJUSTMENT
MAX	SETS MAXIMUM MOTOR SPEED when speedpot is set at maximum (100% rotation CW). CW rotation of MAX trimpot increases maximum motor speed.	<ol style="list-style-type: none"> 1. TURN DRIVE POWER OFF! 2. Connect DC Voltmeter: + to +ARM, - to -ARM. 3. Set meter voltage range: (90VDC or 180VDC). 4. Turn power on. Set speedpot at 100%. 5. Adjust MAX trimpot to rated motor armature voltage as shown on meter. <p>NOTE: A tachometer or strobe may be used in lieu of a meter. Follow above steps, except adjust MAX trimpot to rated motor base speed indicated by tachometer or strobe.</p>
MIN	SETS MINIMUM MOTOR SPEED when speedpot is set at zero. CW rotation will increase minimum motor speed.	<ol style="list-style-type: none"> 1. Set speedpot to zero (fully CCW). 2. Rotate MIN trimpot CW until motor rotates. 3. Slowly rotate MIN trimpot CCW until motor stops. <p>NOTE: If motor rotation at zero is desired, rotate MIN trimpot CW until desired minimum speed is reached.</p>
I.R. COMP.	CALIBRATES SPEED REGULATION Provides a means of improving motor speed regulation in the armature feedback mode. If a slowdown due to load change is of no concern, rotate this trimpot fully CCW.	<ol style="list-style-type: none"> 1. Set speedpot at 50% 2. Observe motor speed at no load condition. 3. Apply a full load to the motor. 4. Adjust IR COMP trimpot CW to obtain the same motor speed as with no load.
CUR. LIM.	LIMITS DC MOTOR ARMATURE CURRENT (Torque) to prevent damage to the motor or control. The current limit is set for the rated motor current. CW rotation of this trimpot increases the armature current (or torque produced).	<ol style="list-style-type: none"> 1. TURN DRIVE POWER OFF! 2. Connect a DC ammeter between A1 on the motor and +ARM on the control. This is in series with the motor. 3. Turn power on. 4. Set speedpot at the 50% position. 5. Set CUR LIM trimpot fully CCW. 6. Apply friction braking to the motor shaft until motor is stalled (zero RPM). 7. While motor is stalled, set current at 125% of rated nameplate motor armature current by adjusting the CUR LIM trimpot.
ACCEL	ALLOWS ADJUSTMENT OF ACCELERATION by user.	<ol style="list-style-type: none"> 1. CW rotation increases time of acceleration.

TRIMPOT SETTING CHART

These settings apply when using a 5000Ω Master Speedpot.
This trimpot chart is approximate. Use it in conjunction with the Adjustment Procedures.

MIN	MAX	ACCEL	I.R.	C.L.	HP	INPUT VOLTS	OUTPUT VOLTS
					1/8	120VAC	0-90VDC
					1/4	120VAC	0-90VDC
					1/3	120VAC	0-90VDC
					1/2	120VAC	0-90VDC
					3/4	120VAC	0-90VDC
					1.0	120VAC	0-90VDC

MIN	MAX	ACCEL	I.R.	C.L.	HP	INPUT VOLTS	OUTPUT VOLTS
					1/4	240VAC	0-180VDC
					1/2	240VAC	0-180VDC
					3/4	240VAC	0-180VDC
					1.0	240VAC	0-180VDC
					1.5	240VAC	0-180VDC
					2.0	240VAC	0-180VDC

DC CONTROL WITH REVERSING

Permits reversing of motor. This is accomplished using a 4PDT blocked center switch. When switched between the forward/ reverse positions, a delay is encountered due to the blocked center position, which protects the control from any voltage that may be at the armature terminals. The center position is OFF/NEUTRAL.

THE MOTOR MUST COME TO A COMPLETE STOP BEFORE CHANGING DIRECTIONS. IF THE MOTOR DOES NOT COME TO A COMPLETE STOP, SERIOUS DAMAGE TO THE CONTROL MAY RESULT. BYPASS OF THE CENTER BLOCK OF THE SWITCH MAY RESULT IN DAMAGE TO THE CONTROL.

A 4PDT blocked center-off switch is factory installed into the cover assembly. The two position terminal strip (P3) is factory installed on the main board (below). The output on P3 is the switched (FWD/REV) output and the output of terminals P1-4 and P1-5 is not switched.

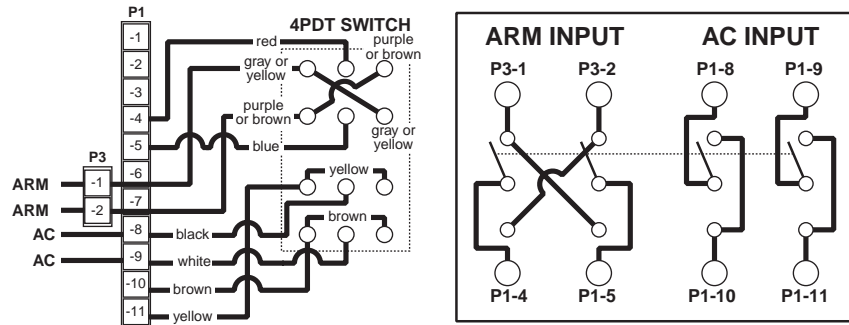

CONTROL MODIFICATIONS

INHIBIT (USED INDEPENDENTLY)

The customer supplied SPST switch is connected in series between the speedpot HI (P1-3) and the Inhibit pin (P2). To inhibit, speedpot HI is closed to the Inhibit pin. To restart, the switch is returned to open. NOTE: The control will stop and start fast, accel is bypassed.

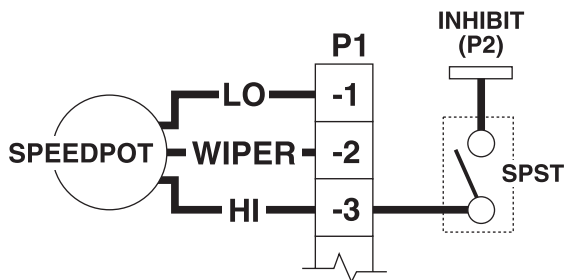

INHIBIT (USED WITH SPEEDPOT)

The Common of the SPDT switch is connected to control pot HI and is switched between Speedpot HI and the Inhibit pin (P2). To inhibit (stop motor), speedpot HI is closed to the Inhibit pin. To restart, the switch is returned to Speedpot HI. NOTE: The control will stop fast and soft start through a fixed acceleration range

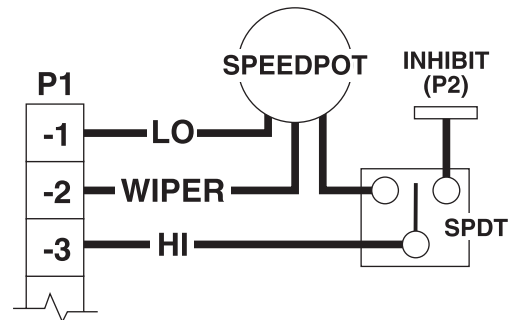

NOTE: Permits starting and stopping of motor without breaking AC lines. In the event of SCR failure or false triggering, the Inhibit circuit will not stop motor.

Always use a shielded wire when connecting to the Inhibit terminal. The shield should be connected to - Armature or Common of the control.

IN CASE OF DIFFICULTY

If a newly installed control will not operate, it is possible that a terminal or connection is loose. Check to make sure that all connections are secure and correct. If control still doesn't operate, refer to the following chart.

PROBLEM	POSSIBLE CAUSE(S)	CORRECTIVE ACTION(S)
Motor doesn't operate	<ul style="list-style-type: none"> - blown fuse - incorrect or no power source - speedpot set at zero - worn motor brushes 	<ul style="list-style-type: none"> - replace fuse - install proper service - adjust speedpot CW to start - replace motor brushes
Armature output voltage cannot be adjusted, output is a constant DC level	<ul style="list-style-type: none"> - no motor or load connected - speedpot low connection open 	<ul style="list-style-type: none"> - check that the motor or load is connected to armature terminals - check that speedpot low wire is connected
Motor stalls, or runs very slowly with speedpot turned fully CW	<ul style="list-style-type: none"> - low voltage - overload condition - worn motor brushes - max speed set incorrectly 	<ul style="list-style-type: none"> - check - should be above 108V - reduce load - replace motor brushes - see ADJUSTMENT PROCEDURE
Motor hunts	<ul style="list-style-type: none"> - too much I.R. Comp. - motor is in current limit - motor not pulling enough current - max trimpot set too high - motor speed is above rated speed 	<ul style="list-style-type: none"> - see ADJUSTMENT PROCEDURE - see ADJUSTMENT PROCEDURE - current must be greater than 150 mA D.C. - see ADJUSTMENT PROCEDURE - reduce speed
Repeated fuse blowing	<ul style="list-style-type: none"> - low voltage - overload condition - worn motor brushes - defective motor bearings - defective electrical component 	<ul style="list-style-type: none"> - check - should be above 108V - reduce load - replace - replace - call WorldWide Distributor or Representative
Motor runs but will not stop	<ul style="list-style-type: none"> - incorrect wiring - defective wiring - defective component 	<ul style="list-style-type: none"> - check TERMINAL STRIP WIRING for correct wiring instructions (note AC line connection in particular) - check wiring - call WorldWide Distributor or Representative

If control still will not operate, consult your WorldWide Electric Distributor or Representative.

SPECIFICATIONS

AC input voltage ±10% of rated line voltage
 Acceleration 0.5 to 8.0 seconds
 Amps - DC output 150 mA to 10.8 Amps D.C.
 Controller overload capacity 150% for one minute
 Current limit trimpot range 1.0 to 15.0 Amps D.C.
 Deceleration (dependent on acceleration time setting)06 to .80 second range
 Dimensions and weight:

	WIDTH	LENGTH	HEIGHT	WEIGHT
ENGLISH	5.53"	7.25"	3.5"	25.5"
METRIC	140 mm	184 mm	89 mm	723 grams

Drive service factor 1.0
 Efficiency 85% typical
 Input frequency 50 or 60 Hertz
 Max. trimpot speed range 66% to 110% of base speed
 Min. trimpot speed range 0% to 30% of maximum speed
 Minimum external impedance (pot hi to pot low) 5K ohms
 Power devices packaged full wave bridge
 Shunt field voltage 100VDC for 120VAC input; 200VDC for 240VAC input; 1 amp maximum
 Speed control via 5K ohms 2W linear potentiometer or 0-10VDC isolated signal
 Speed range 50:1
 Speed regulation ±1% of base speed
 Temperature range -10° to 45° C. ambient (15° to 115° F.)
 Transient protection G-Mov
 Type ramp of accel/decel linear

TYPICAL MOTOR CURRENTS

Horsepower	1/4	1/3	1/2	3/4	1	1.5	2
Typical AC Amps (120VAC)	3.5	4.4	6.5	9.3	13.2	---	---
Typical Arm Amps (120VAC)	2.7	3.4	5.0	7.2	10.2	---	---
Typical AC Amps (240VAC)	1.8	2.2	3.3	4.8	6.5	9.7	12.9
Typical Arm Amps (240VAC)	1.4	1.7	2.5	3.7	5.0	7.5	9.9

WDC SERIES PARTS PLACEMENT & LIST

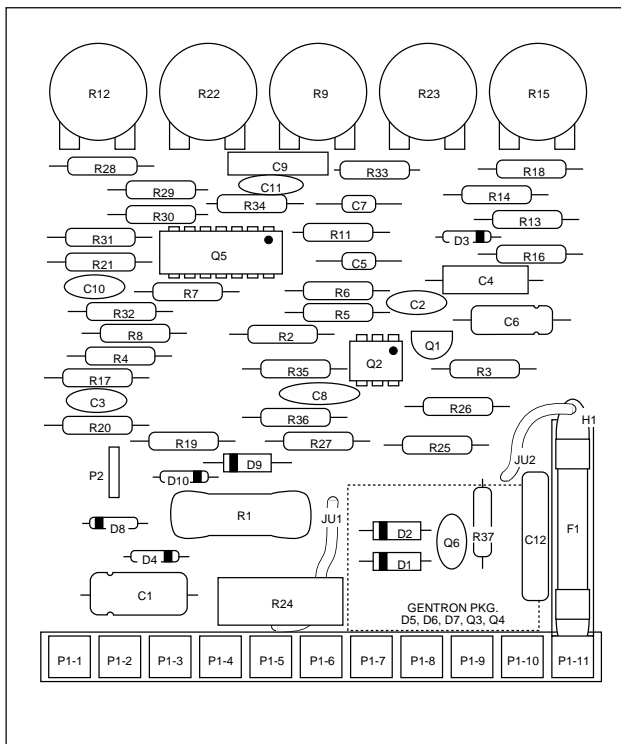

NOTE: ALL RESISTORS 1/2W UNLESS SPECIFIED

RESISTOR

R1	15K 8W	R20	1K
R2	2.7K	R21	1K
R3	2.7K	R22	50K (MAX)
R4	1.2M	R23	100Ω (I.R.)
R5	180K	R24	.01Ω 5W
R6	82K	R25	390Ω
R7	470K	R26	390Ω
R8	15K	R27	1K
R9	250K (ACCEL)	R28	20K 1/4W
R10	5K SPEEDPOT*	R29	10K
R11	10K	R30	180K
R12	5K (MIN)	R31	390K
R13	470K	R32	47K
R14	300K	R33	470K
R15	5K (C.L.)	R34	100K
R16	4.7K	R35	470Ω
R17	390K	R36	91K
R18	4.7K	R37	1Ω
R19	150K		

CAPACITOR

C1	10uf 35V
C2	.01uf 100V
C3	.001uf 1KV
C4	.033uf 400V
C5	.1uf 50V
C6	.22uf 16V
C7	.1uf 50V
C8	.0047uf 1KV
C9	.22uf 250V
C10	.01uf 100V
C11	.01uf 100V
C12	.068uf 250V (across-the-line)

DIODES ACTIVE

D1	1N4005	Q1	2N6027
D2	1N4005	Q2	3052 MOC
D3	1N914B	Q3	L512FY131
D4	1N5242B	Q4	L512FY131
D5	L512FY131	Q5	LM324N IC
D6	L512FY131	Q6	275V
D7	L512FY131		
D8	1N914B		
D9	1N4005		
D10	1N5233B		

MISC.

F1	10 AMP FUSE (Bussman ABC or Little Fuse 314 Series ceramic fuses)
H1	S-8201-1X FUSE HOLDER
JU1	1.75" - 16GA. SOLID INS. WIRE
JU2	2.50" - 16GA. SOLID INS. WIRE
P1	11 POS. TERMINAL STRIP
P2	1/4" SPADE PIN TERMINAL

WDC SERIES SCHEMATIC

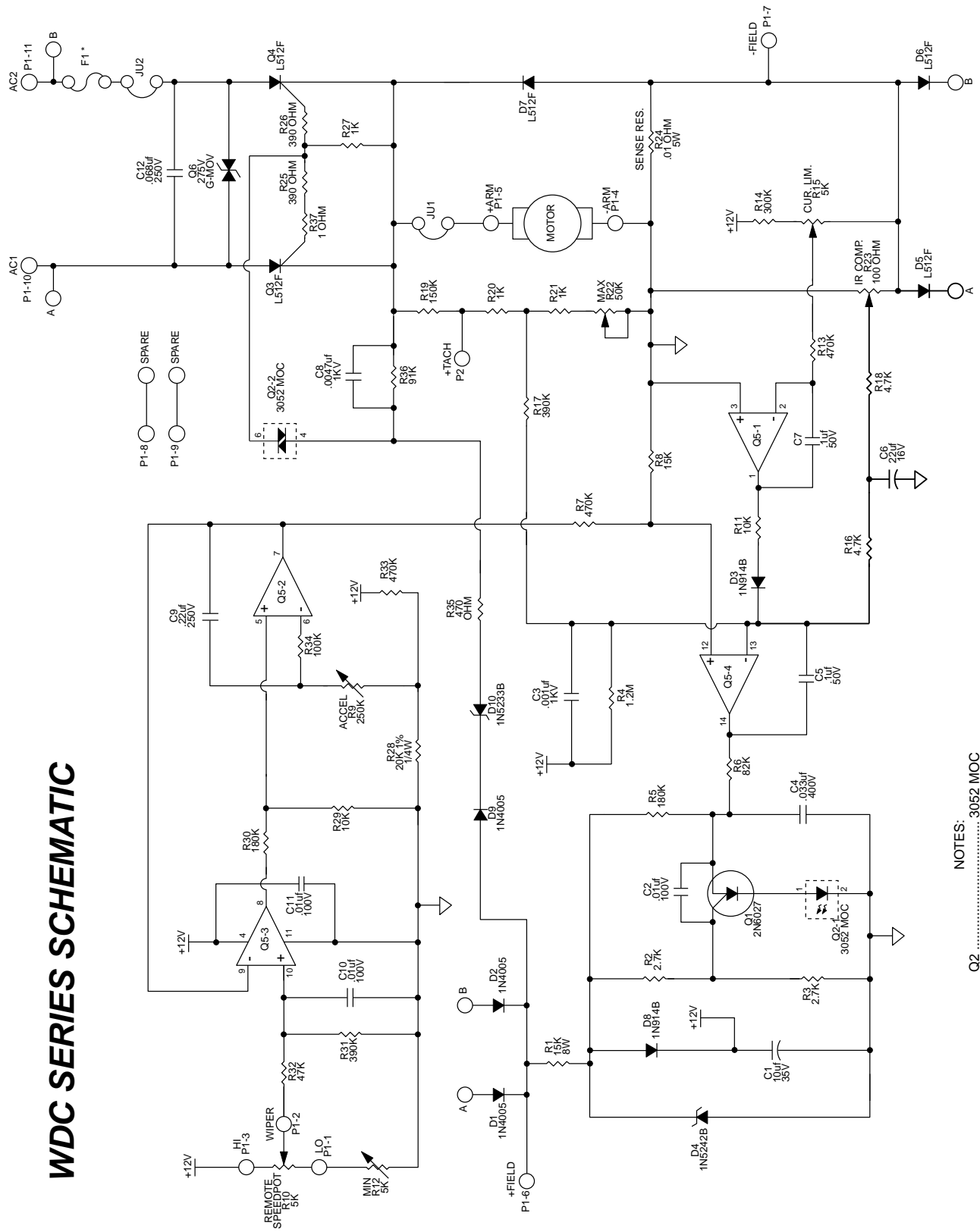

- NOTES:
- Q2 3052 MOC
 - Q3, Q4, D5, D6, D7 L512FV131 GENTRON
 - Q5 LM1224N1C
 - Q6 3052 MOC
 - F1 BUSS ABC-10 or LITTLEFUSE 314010

ALL RESISTORS 1/2W UNLESS NOTED OTHERWISE