

**EFFICIENCY SERIES**



# Instruction Manual

## Variable Frequency Drive 1 - 5 HP Controls



P.O. Box 307  
1 Grove Street - Suite 201B  
Pittsford, NY 14534

Phone: (800) 808-2131  
Fax: (800) 711-1616  
WorldWideElectric.net

# Table of Contents

---

---

## Overview – Safety and Precautions (Review before Installation)

OV-1 Installation Considerations	1
OV-2 Wiring Considerations	2
OV-3 Operation Considerations	3
OV-4 UL Standards	4
OV-5 Product Verification	7
OV-6 WVEVFD Output Ratings	8
OV-7 WVEVFD General Specifications	9
OV-8 Wire Size Specification	11
OV-9 Derate - Altitude/ Switching Freq / Single Phase Input	12

## Section A - Installation

A-1 Mounting Considerations	14
A-2 Power Terminal Connections	15
A-3 Input and Output Terminals	16
A-4 Control Board Layout	20
A-5 Drive Case Removal	21

## Section B - Keypad Programming and Operation

B-1 Keypad Overview	22
B-2 Digital Keypad Overview	22
B-3 Display Options	23
B-4 Terminal Status Display	23
B-5 Examples of Parameter Programming	24
1. Start command, 2. Acceleration, 3. Reset to Factory Settings	
4. Uploading a program to the Keypad	
5. Downloading a program to a different drive from the keypad	
6. Changing the to show RPM's	

## Section C - Parameter Table

C-1 Keypad	31
C-2 Preset Speeds	33
C-3 Acceleration/ Deceleration	34
C-4 Drive Output Parameters	35
C-5 Analog Inputs	37
C-6 Analog Outputs	38
C-7 Motor Data and Protection	38
C-8 Digital Inputs	39
C-9 Digital Outputs	40
C-10 Miscellaneous	41
C-11 Parameter List Key	42

# Table of Contents

---

---

## Section D - Parameter Descriptions

Parameter Index	47
D-1 Keypad	48
D-2 Preset Speeds	51
D-3 Acceleration/ Deceleration	52
D-4 Drive Output Parameters	53
D-5 Analog Inputs	56
D-6 Analog Outputs	58
D-7 Motor Data and Protection	59
D-8 Digital Inputs	59
D-9 Digital Outputs	64
D-10 Miscellaneous	67

## Section E - Terminal Wiring Connection for Operation

E-1 Keypad Speed Control – with Forward and Reverse	69
E-2 3-Wire Start/Stop Control Circuit (Standard Run)	70
E-3 2-Wire Circuit for 3-Preset And Analog Speed Control	71

## Section F - Troubleshooting

F-1 The difference between a Fault and Warnings Message	73
F-2 Troubleshooting Fault and Warning Messages	73
1. OC, 2 OE, 3. GF, 4.OL, 5. OL1, 6. OH, 7. LE, 8.LE1, 9. EEr, 10. Bb, 11. db, 12. deF, 13. Fr, 14. thr, 15. AdEr, 16. Err 00, 17. Err 01, 18. UUr-F,	
F-3 Additional Issues and Suggestions	80
F-4 Digital Input and Output Diagnostic Display	81

## Appendix I - Outline Drawings

A1-1 Keypad Drawings	App I-1
A1-2 Drive outline Drawing	App I-1
A1-3 Drive Outline Drawing with NEMA1 Enclosure	App I-2
A1-4 Dimensions for Mounting WWE-201KP-Keypad	App I-2
A1-5 Keypad Door Mount – A01	App I-3

## Appendix II - Drive Accessories

A2-1 Resistor Values for External Brake Resistors	App II-1
A2-2 Dynamics Brake and Resistor	App II-2



## Overview

### SAFETY and PRECAUTIONS

Before installation, wiring, maintenance, or trouble shooting, please read this manual thoroughly and pay attention to the safety precautions marked with “**Danger**” or “**Caution**” in this manual. Information that be helpful in certain sections will have “**Note:**” or “**Warning:**” if there is potential for harm or equipment failure.

Only qualified personnel should install, wire, test, setup, or troubleshoot.

- ※ **Qualified Personnel:** must be familiar with the fundamentals, structures, characteristics, operating procedures, for the installation of electrical and specifically VFD installations information. This person must read the manual in detail and follow the steps of security measures to prevent possible danger.

 <b>DANGER</b>	User may cause the casualty or serious damages if user does not abide by the instructions of the manual to execute the tasks.
 <b>CAUTION</b>	User may cause injuries to the people or damage the equipment if user does not abide by the instructions of the manual to execute the tasks,

- ※ The “” mark indicate less serious potential for damage or injuries however the user should be aware and consider the warning information.

#### OV-1 Installation Considerations

 <b>CAUTION</b>
<ol style="list-style-type: none"><li>1. The installation shall take place only on metal surface or materials that are fire resistant. Locations with high ambient (above 50C), moisture, oil and gas fumes, cotton fiber, metal powder and corrosive fumes must be avoided.</li><li>2. If the product specification indicates IP00 (the protective level of the equipment structure), the installation location must prevent human contact when power is applied to avoid the electric shock. The installation of Reactors, Filters or additional braking should be done only when there is no power to the drive.</li><li>3. Ambient temperature shall not exceed 50°C (122°F) including inside an enclosure.</li></ol>

## Overview

### OV-2 Wiring Considerations



#### DANGER

1. When wiring the drive disconnect all power to avoid electric shock.
2. L1, L2, and L3 are power inputs and T1, T2, and T3 are the drive's outputs to the motor. Do Not connect input and output leads to terminals DC+, DC- and PR.
3. Once the wiring is complete, the drive terminal cover must be replaced to protect from accidental contact.
4. 230V drive must not be connected to an electric source of 346 – 600 Volts.
5. G  terminal must be properly grounded. Grounding must be confirmed with the requirements of the National and local electric code.
6. Please refer to "UL" in the Overview Section OV 4 of the manual for Wire size and tightening torque, and terminal screw size.



#### DANGER

7. Please refer to the National and local electric codes for the appropriate wire Specification.
8. The appropriate Molded Case Circuit Breaker (MCCB) or Fuse must be installed on the drives input power leads (L1, L2, L3).
9. For multiple motors powered by a single drive a Thermal Overload Relay must be installed for each motor.
10. Do not connect power factor correction capacitor, surge arrester, or Single Phase motor to the drive's Output (T1, T2, T3).
11. If the input transformer is 500kVA or 10 times or more than the drive rated capacity and input reactor is recommended.
12. Do not touch the drive or perform any wiring actions before drive indicator light turns off. Wait at least 5 minutes or use a multi-meter with it set to DC voltage measuring between DC(+) and DC(-) terminal (The voltage must be less than 50V). **Note:** the meter must be suitable for 1000VDC.



#### CAUTION

13. Do not use the drive for any other purpose than to drive a three phase AC Induction Motor.
14. The Power Leads and Control Circuit wires must be kept separated crossing at right angles. Control circuit wiring must use shielded or twisted-pair shielded wires to avoid possible interferences resulting in erratic drive operation.

### OV-3 Operation



#### DANGER

1. Do not open or remove the terminal cover while power is "On" or during the drive operation. Close the terminal cover before applying power to the drive. Do not remove the cover except for wiring or periodic inspection and only when power is "off".
2. At the function F\_078= "1" or "3", the drive will automatically restart when faulted or power is restored. Setting this parameter to "Auto restart" should only be considered if it can be done safely and the drive can be "locked out" when being serviced.
3. At the function F\_003=0 and F\_001=0 or 1, the **STOP** key on the keypad is "disabled". An Emergency Stop must be connected and its operation confirmed.
4. The drive can generate extremely high-speeds for a standard AC motor. Before adjusting the drive's max speed, confirm the motor can operate without damage to the new max speed setting.
5. If any protective functions have been activated, check the run command inputs are "Off" (this may require opening the case) only then "Reset" the drive.



#### CAUTION

6. Do not touch the heat sink or brake resistors due to the potential High Operating Temperatures.
7. The DC brake functions (F\_075~077) is not a substitute for a mechanical holding brake.

### OV-4 UL Standards



#### CAUTION

1. "Risk of Electric Shock"  
Before starting or inspection, turn OFF the power and wait at least 5 minutes, and check for residual voltage between terminal DC+ and DC- with a multi-meter or similar instrument has dropped to the safe level (50 VDC or below), to avoid a hazard of electric shock.
2. These devices are intended for use in Pollution Degree 2 environments. (non conductive dust)
3. Maximum Ambient Air Temperature 50°C (122°F).
4. Short circuit rating  
"Suitable For Use On A Circuit Capable Of Delivering Not More Than 5000 rms Symmetrical Amperes, 240V Maximum for 230V class" Models WWE-VFD; rated for 230V class input. "Suitable For Use On A Circuit Capable Of Delivering Not More Than 5000 rms Symmetrical Amperes, 480 V Maximum for 460V class" Models WWE-VFD; rated for 460V class input. "Integral solid state short circuit protection does not provide branch circuit protection. Branch circuit protection must be provided in accordance with the National Electrical Code and any additional local codes."

## Overview



### CAUTION

5. Install UL certified branch circuit fuse between the power supply and the inverter, referring to the table below.

#### 230V Single-Phase Series

WWEVFD	Fuse type	Fuse	A
WWEVFD-12-230-1P	Class RK5 250 Vac, 200kA.I.C.	FRN-R-10	10
WWEVFD-1-230-1P		FRN-R-20	20
WWEVFD-2-230-1P		FRN-R-50	50

#### 230V Three-Phase Series

WWEVFD	Fuse type	Fuse	Amp
WWEVFD-12-230	Class RK5 250 Vac, 200kA.I.C.	FRN-R-5	5
WWEVFD-1-230		FRN-R-10	10
WWEVFD-2-230		FRN-R-15	15
WWEVFD-3-230		FRN-R-20	20
WWEVFD-5-230		FRN-R-30	30

#### 460V Three-Phase Series

WWEVFD	Fuse type	Fuse	Amp
WWEVFD-1-460	Class RK5 600 Vac, 200kA.I.C.	FRS-R-5	5
WWEVFD-2-460		FRS-R-10	10
WWEVFD-3-460		FRS-R-15	15
WWEVFD-5-460		FRS-R-20	20

## Overview

### OV-4 UL Standards (continued)



### CAUTION

6. Main circuit terminal wiring - "Use 65/75°C Cu wire only." Recommend using UL-listed closed-loop connectors or CSA-certified ring connector's size, use the correct crimp tool to install connectors per manufacturer recommendation. Suitable closed-loop connectors manufactured by K S TERMINALS INC. See table below for main circuit wire size.

#### 230 V Three-Phase Series

WWEVFD	Terminal screw	Tightening torque lb-in	Wire size AWG		
			L1 L2 L3 Grounding ( ⊕ )	T1 T2 T3	
WWEVFD-12-230	M4* or #8	13.8	16	16	
WWEVFD-1-230					
WWEVFD-2-230			14	14	
WWEVFD-3-230					
WWEVFD-5-230			10	10	
WWEVFD-12-230-1P			16	16	
WWEVFD-1-230-1P					
WWEVFD-2-230-1P					

#### 460 V Three-Phase Series

WWEVFD	Terminal screw	Tightening torque lb-in	Wire size AWG		
			L1 L2 L3 Grounding ( ⊕ )	T1 T2 T3	
WWEVFD-1-460	M4* or #8	13.8	18	18	
WWEVFD-2-460					
WWEVFD-3-460			16	16	
WWEVFD-5-460			14	14	

\*Grounding terminal size is No. 8 (0.164 in).

#### Closed-loop crimp terminals size

Wire gauge AWG (mm <sup>2</sup> )	Terminal screw	Crimp terminal model numbers
18	M4 (or # 8)	RDL1-4
16		RDL2-4
14		
12		RDS5-4
10		

# Overview

## OV-5 Product Verification

- Confirm the drive's model number is identical with the model number on the carton.
- Confirm the drive nameplate (figure below) to verify the product is correct.

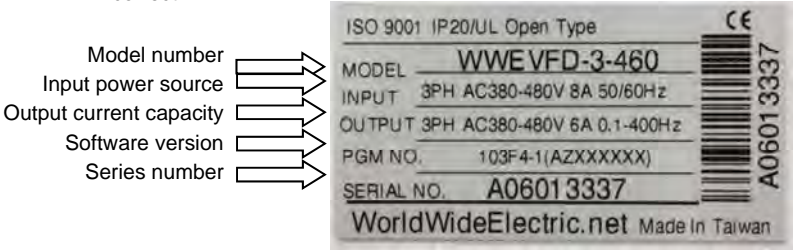

## Part number explanation

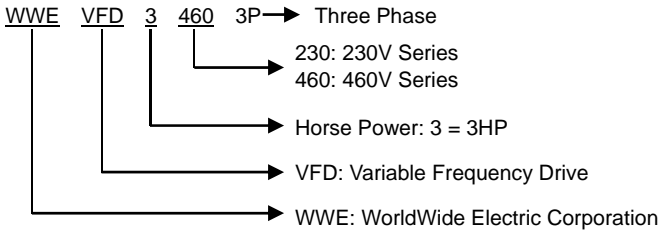

## Overview

### OV-6 WVEVFD Output Ratings

#### WVEVFD-230V Three-Phase Series

Type name	WVEVFD -12-230	WVEVFD -1-230	WVEVFD -2-230	WVEVFD -3-230	WVEVFD -5-230
Maximum applicable motor HP/kW	0.5/0.4	1/0.75	2/1.5	3/2.2	5/3.7
Rated output capacity (kVA)	1.1	1.9	3	4.2	6.5
Rated output current (A)	3	5	8	11	17
Range of output frequency (Hz)	0.1~400.00 Hz				
Overload protection	150% over rated output current / 1 min.				
Input current (A)	5	6	10	14	18
AC Input Range	176~264 V 50/60 Hz / $\pm 5\%$				
Cooling system	Convection		Fan		
Applicable safety standards	UL508C				
Enclosure Rating	IP20, UL open type				
Weight / Mass (Lbs/kg)	4/1.8	4/1.8	4.2/1.9	4.4/2	4.6/2.1

#### WVEVFD-460V Three-Phase Series



Type name	WVEVFD -1-460	WVEVFD -2-460	WVEVFD -3-460	WVEVFD -5-460
Maximum applicable motor (HP/kW)	1/0.75	2/1.5	3/2.2	5/3.7
Rated output capacity (kVA)	1.9	3	4.6	6.9
Rated output current (A)	2.5	4	6	9
Range of output frequency (Hz)	0.1~400.00 Hz			
Input current (A)	3.5	5	8	12
AC Input Range	332~528 V 50/60 Hz / $\pm 5\%$			
Overload protection	150% over rated output current / 1 min.			
Cooling method	Convection		Fan	
Applicable safety standards	UL508C			
Enclosure Rating	IP20, UL open type			
Weight / (Lbs)	4	4.2	4.4	4.4

#### WVEVFD-230V Single- Phase Series

## Overview

Type name	WWEVFD-12-230-1P	WWEVFD-1-230-1P	WWEVFD-2-230-1P
Maximum applicable motor (HP/kW)	0.5/0.4	1/0.75	2/1.5
Rated output capacity (kVA)	1.1	1.9	3
Rated output current (A)	3	5	8
Rated output voltage (V)	Three-phase 200-240 V		
Range of output frequency (Hz)	0.1~ 400.00 Hz		
Power source ( $\phi \cdot V \cdot \text{Hz}$ )	Single-phase 200~240 V 50/60Hz		
Input current (A)	7	13.5	19
Permissible AC power source fluctuation	176~264 V 50/60 Hz / $\pm 5\%$		
Overload protection	150% over rated output current / 1 min.		
Cooling system	Natural cooling		Fan cooling
Applicable safety standards	UL508C,		
Protective structure	IP20, UL open type		
Weight /(Lbs)	3.96	4.18	4.4

### OV-7 WWEVFD - General Specifications

Item		Description
User interface		Digital keypad with remote control
Control resolution	Control method	Voltage vector sinusoidal PWM control
	Range of frequency setting	0.1~400.00 Hz
	Resolution of frequency setting	Digital keypad: 0.01 Hz Analog input: 0.06/60 Hz
	Resolution of output frequency	0.01 Hz
	Analog Input for frequency setting	DC 0~10 V (20 k $\Omega$ ), 4~20 mA (250 $\Omega$ )
	Overload protection	150% drive rated current for 1 minute (inverse time characteristics)
	Five steps acc. / dec. times	0 second (coast to stop), 0.1~3200.0 seconds (each setting of acc. and dec.) 0.015 ~ 3200 sec (Acceleration from 0 to 60Hz)
	Braking torque	Approx. 20% (with build-in braking transistor can reach 100%)
	V/F curve	Adjustable V/F curve can be set.
	Stall prevention	Adjustable setting for fold back preventing stall or drive trip
Item		Description
  	Start method	Forward (FWD) / reverse (REV) rotation, 3-wire self-holding

## Overview

			FWD/REV control, or 9-speed control can be selected
		Multi-function inputs	Stop command by 3-wire start/stop, jogging operation, secondary acc/dec time, multi-speed command 1~3, reset alarm, external fault command, command of inhibiting output, coast to a stop, max. frequency search command, frequency setting search command, acc/dec inhibition command, UP/DOWN command, UP/DOWN frequency command clear/enter, analog input select, DC braking enable, current limit enable
		Analog inputs	Vin-GND (0~10 V), Iin-GND (4~20 mA / 2~10 V or 0~20 mA / 0~10 V)
	Output	Multi-function outputs	Running, constant speed, zero speed, frequency, overload, stall prevention, under-voltage, braking detections, restart after fault, fault condition, and instantaneous power interruption to restart detections, programmable Form C and Normally Open
		Analog outputs	Analog signal (DC 0~10 V) output, adjustable gain, output frequency selection, frequency setting or output current
Display	Keypad display	Frequency output, frequency setting, voltage output, DC bus voltage, current output, motor RPM, linear speed, terminal status	
	External display (external connection)	Independent external display can be added for up to three sets (96 mm x 48 mm, 5 digits) to show voltage, current, frequency, linear speed, etc.	
Protection	Fault Protection	Over-current (OC), over-voltage (OE), low-voltage (LE), motor overload (OL), drive overload (OL1), overheat (OH), fuse open (SC), ground fault (GF), voltage low during running (LE1)	
Environment	Atmosphere	Non-corrosive or non-conductive, or non-explosive gas or liquid, and non-dusty	
	Surrounding temperature	-10°C (14°F) ~ +50°C (122°F) non-freezing and non-condensing	
	Storage temperature	-20°C (-4°F) ~ +60°C (149°F)	
	Relative humidity	90% RH or less (no-condensing atmosphere)	
	Vibration	Less than 5.9m/sec <sup>2</sup> (0.6G)	
	Altitude	Less than 1000m (3280 ft.)	

## Overview

### OV-8 Wire Size Specification

#### WWEVFD-230V Three-Phase Series

Model no. WWEVFD	Input current (A)	MCCB (A)	Main circuit wire size (AWG)	Control circuit wire size (AWG)	Grounding wire size (AWG)
WWEVFD-12-230	3.8	5	14	18-16	14
WWEVFD-1-230	6	10	14		14
WWEVFD-2-230	9	15	14		14
WWEVFD-3-230	12	20	14		14
WWEVFD-5-230	22	30	11		11

#### WWEVFD-460V Three-Phase Series

Model no. WWEVFD	Input current (A)	MCCB (A)	Main circuit wire size (AWG)	Control circuit wire size (AWG)	Grounding wire size (AWG)
WWEVFD-1-460	3.5	5	14	18-16	14
WWEVFD-2-460	4.8	10	14		14
WWEVFD-3-460	8	15	14		14
WWEVFD-5-460	11	20	11		14

#### WWEVFD-230V Single- Phase Series

Model no. WWEVFD	Input current (A)	MCCB (A)	Main circuit wire size (AWG)	Control circuit wire size (AWG)	Grounding wire size (AWG)
WWEVFD-12-230-1P	7	10	14	18-16	14
WWEVFD-1-230-1P	13.58	20	14		14
WWEVFD-2-230-1P	20	30	14		14

Note :

1. Please refer to the local electric code with respect to the wiring.
2. Please use cable that is suitable for 600 V 75°C above.
3. This chart is for reference only.

## Overview

### OV-9 Derate - Altitude / Switching Freq / Single Phase Input Altitude Derate

If the drive is used at the altitude greater than 1000 m, the relationship of drive's rated current and altitude is shown in the below figure.

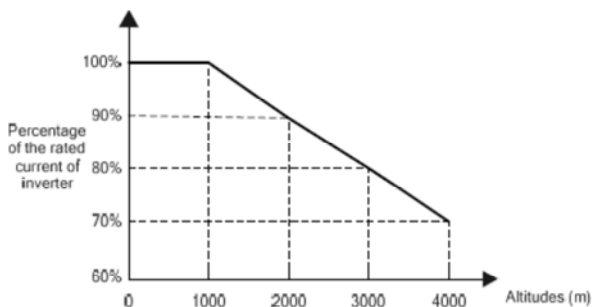

Example if a drive is used at 3000 Meters (+10,000Ft) it will only be rated for 80% of the amperage on the nameplate.

### Switching Frequency Verse Cable Length

Using higher switching frequency increases leakage current in cabling from the drive to the motor. To minimize the leakage current reduces the switching frequency with increased cable length per the table below.

Distance \ Rated power	10 m	20 m	30 m	50 m	100 m	Over 100 m
1/2~5Hp	10kHz	7.5kHz	5kHz	2.5kHz	800Hz	800Hz
F_081 Setting	4	3	2	1*	0	0

**\*Factory Setting**

#### Notes:

When F\_081 sets the PWM switching frequency from 0-6, as the switching frequency is increased motor noise will decrease. The output transistors heating will increase as well. Occupying the higher switching frequency can shorten transistor's life of a drive. Unless necessary, keep the switching frequency as low as possible.

## Overview

---

### Single-Phase Input to a Three phase Drive Derate

If Single phase power is used a 50% derate, the drives output by 50%.

### Single-phase 230V series

Drive HP	1/2HP	1HP	2HP	3HP	5HP
DeRated Output Current	1.5 A	2.5 A	4 A	5.5 A	8.5 A

## Section A Installation

### A-1 Mounting Consideration

The drive must have a proper short circuit protection from a Molded Case Circuit Breaker (MCCB) or Fuse – See OV-4. The drive should be mounted in an environment that is dry, without dust, oily or flammable material to ensure the proper drive operations.

### Installing the Drive

Proper Mounting – the drive does create heat during operation. Provide proper air circulation, with a minimum clearance (shown in the below figure) for proper operations.

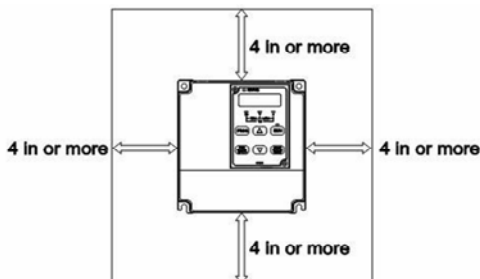

### Additional Consideration for Mounting

Mounting inside an enclosure does require proper ventilation. The drive does create heat, and forced ventilation is recommended to prevent overheating. Heat from other drives or other equipment must not be vented in to another drive. Vent and divert exhaust heat from all devices.

#### Correct

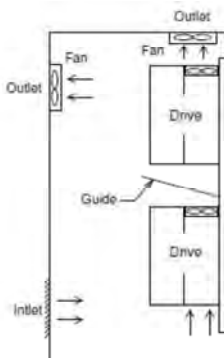

#### Incorrect

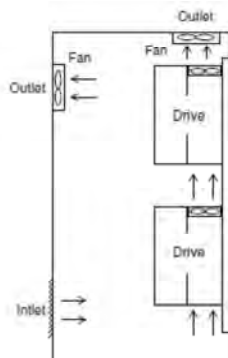

**Warning:** DO NOT put Power Factor Capacitors on the output of the drive.

**Note:** The drive should be in a clean, non-condensing environment.

## Section A Installation

### A-2 Power Terminal Connections

#### -Single-Phase Power Terminal Connection

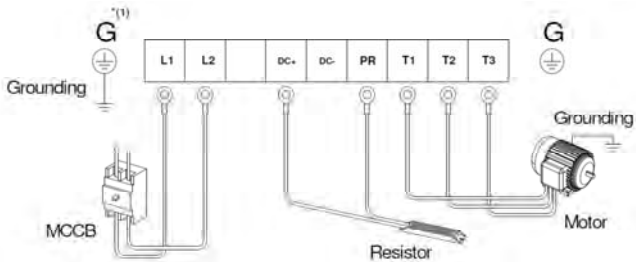

#### -Three-Phase Power Terminal Connection

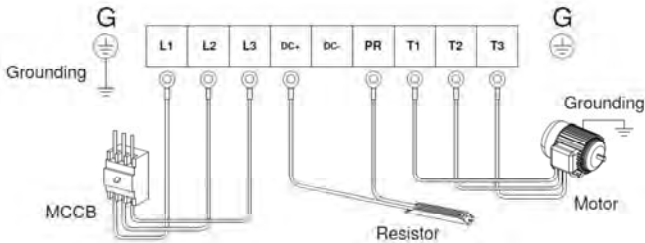

Model number	Terminal screw size	Tightening torque lb-in	Grounding terminal size	Tightening torque lb-in
WWEVFD-12-230 1P~ WWEVFD-2-230-1P WWEVFD-12-230 ~ WWEVFD-5-230 WWEVFD-1-460 ~ WWEVFD-5-460	M4	15.6	No. 8	15.6

**Note:** Please see Overview Section OV-4 for more information on proper circuit protection, wire gauge, and torque tightening requirements.

## Section A Installation

### A-3 Input and Output Terminals

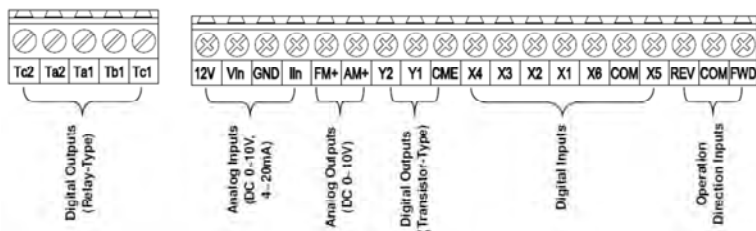

**Note:** All input wires must be shielded with the shield terminated to the same “COM” or “GND” terminal that is associated with the input.

**Example:** Y2 and Y1 shield must be terminated in CME.

**Warning:** Do NOT run Low voltage wires in the same conduit or wire way with High Voltage wires **Note:** See Overview Section OV-4 for wire gauges of input wires (and power cables).

### Input Terminals

**Digital Inputs Terminals X4 – FWD** - can be Sink or Source.

The Default is “Sink” – where a dry contact is used as the input and powered by the drive. See the connection diagrams below for sink and source connection options. To change from “Sink” to “Source” input, see section A-4 for info on changing “SW2” on the control board.

Each input has multifunction capabilities including operating in reverse logic. **Example:** default of an input switch “Closing” sets an input if changed to reverse logic a switch “Open” sets an input. – see parameter F\_052 ~ F\_057 To change to reverse logic set the parameter to a “-” setting.

**Sink Examples – default** Power supplied by the drive for the input devices – **most common arrangement.**

See Section E for more input connection and operation examples.

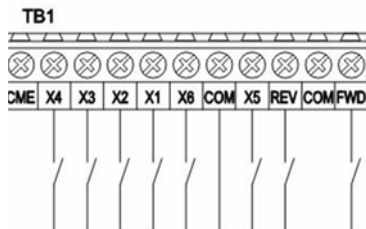

## Section A Installation

### Sink Example: Typical PLC (NPN)

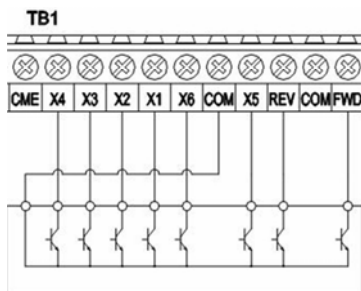

**Source Examples: PLC (PNP)** The terminal power is supplied by the external source. **Note SW2 must be changed**

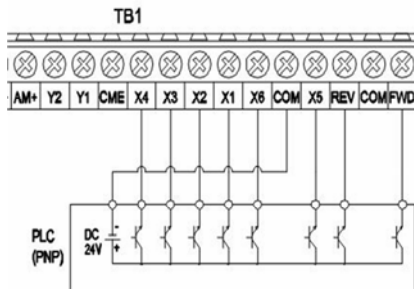

**Analog Input Terminals “12V” to “lin”** – provide for a current or voltage analog input.

**Current Input** – The default is current input (4-20mA) using “lin” and “GND”. To program the analog inputs, see section C for parameter F\_124 ~ F\_128 setting.

## Section A Installation

**Voltage Input** – To use a Pot or 0-10VDC for input. To program the voltage input, see section C for parameter F\_123 and F\_124. **Note:** To change the drive for voltage input switch “SW1” on the control board – see Section A-4

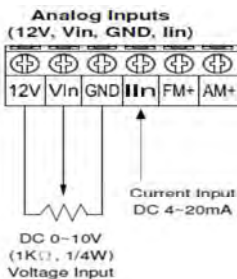

**Note: Voltage input** – Use 12V, Vin and GND with a 1KΩ, 1/4 Watt potentiometer. For 0-10VDC input use “Vin” and “GND” terminals.

### Output Terminals

**Digital outputs – Relay – Ta1, Tb1 and Tc1** – is a form “C” SPDT contact and Ta2, and Tc2 is a N.O. contact all are rated AC 250V, 0.5 Amps.

**Note:** These contacts are NOT suitable for operating contactor coils and should be used for interfacing only.

These are digital outputs - see parameter F\_060 and F\_131. They can also be changed to have reverse operation by changing the parameter from F\_060 and F\_131. The default output configuration is shown the diagram below.

**Digital Outputs Terminal Y2- CME** – Two solid state outputs “Open Collector” that can be programmed using F\_058 ~ F\_059. **Note:** Maximum rating is 48VDC/ 50mA and should not be used to drive any inductive loads such as coils.

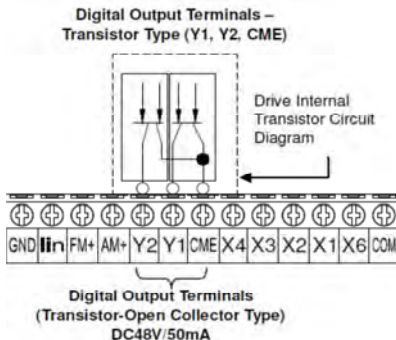

## Section A Installation

**Analog Output Terminals - AM+, FM+, and GND** – These are multifunction analog outputs with a range from 0~10VDC. See parameters F\_129 and F\_130 settings for “AM+” and see parameter F\_044 and F\_045 for settings for “FM+”.

**Note:** Typical usage is for analog meters such as a Frequency Meter and Amp Meter.

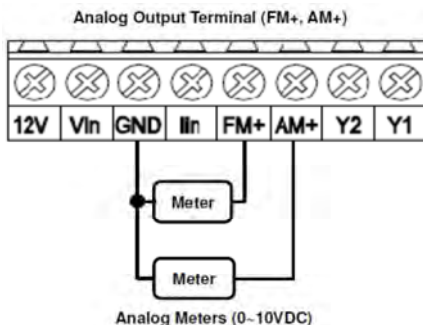

## Section A Installation

### A-4 Control Board Layout

**230V Series:** WWEVFD-12-230-1P ~ WWEVFD-2-230-1P

**230V Series:** WWEVFD-12-230 ~ WWEVFD-5-230

**460V Series:** WWEVFD-1-460 ~ WWEVFD-5-460

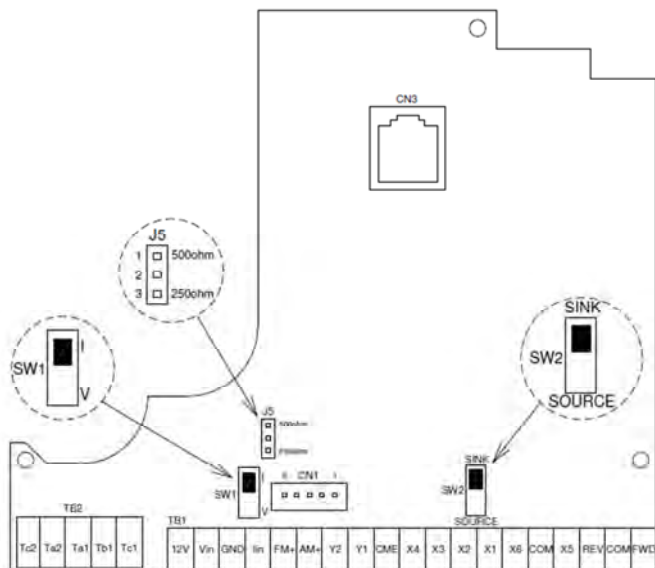

**CN1:** Connector for external displays.

**CN3:** RJ-45 connector for keypad

**TB1:** Analog and digital input and output terminals

**TB2:** Digital output terminals (Relay type)

**SW1:** Selects current or voltage input default is Current ("lin")

**SW2:** Multi-function Input terminal (**X1~X6, FWD, REV**) **SINK/SOURCE** signal selection switch

**J5:** "lin" input impedance options- to select 500Ω impedance jumper pin 1 and 2. For 250Ω impedance jumper pin 2 and 3.

**Note:** The default is for 250Ω

**Note:** To change J5, the drive case cover must be removed.

See A-5 case removal instructions.

## Section A Installation

### A-5 Drive Case Removal to change J5 Jumper.

**Warning:** This should only be done with all power lead disconnected and the bus completely discharge. Severe shock hazardous would be otherwise present!! Do not reconnect power leads until case is full reinstalled.

To release the cover remove the two screws from the bottom left and right corner of the drive – see drawing.

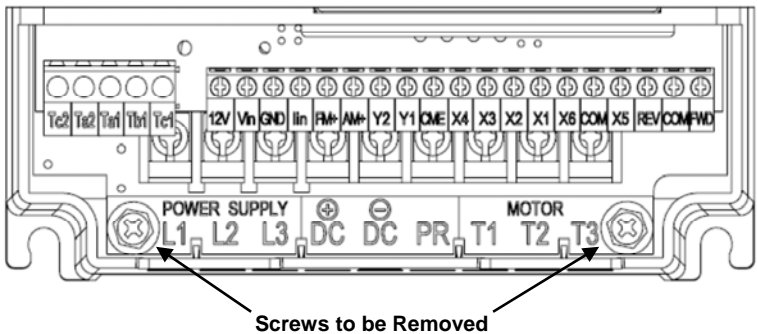



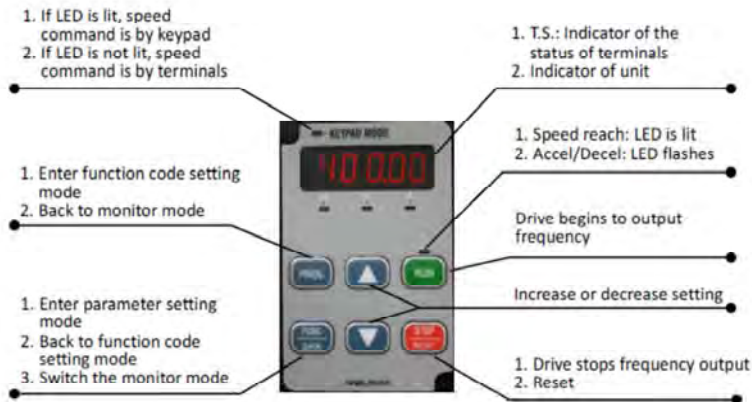

## Section B Keypad Programming and Operation

### B-1 Keypad Overview

This sections will show how the Digital keypad can change parameters, monitor output, and troubleshoot drive Faults and Warnings. Use this section for keypad programming basics. Parameter descriptions are in Section C.

























































### B-2 Digital keypad Overview

	Enter the Parameter setting Mode and save a “New” value setting. Will also return the Keypad to Monitor Mode
	Starts output to the motor (“Start” Button) Run LED “On”: Drive under operation LED “Blinking”: Drive under Accel/Decel or Keypad upload/ Download
	Enter a New Parameter value (but does not save the setting). Return to the monitor mode.
	Drive begins the “Stop” Cycle Reset / fault message – clears the message
	LED indicator – indicating the keypad under power and operational

## Section B Keypad Programming and Operation

### B-3 Display Options

	<p>The LEDs marked “HZ”, “V”, “A” under the Display show which Mode the Keypad display is operating. as programmed in F_006</p>																								
<p><b>LED Legend</b></p> <table style="width: 100%; border-collapse: collapse;"> <tr> <td style="text-align: center;">  </td> <td style="text-align: center;">  </td> <td style="text-align: center;">  </td> <td style="padding-left: 10px;">Hz - Hertz's – Default</td> </tr> <tr> <td style="text-align: center;">  </td> <td style="text-align: center;">  </td> <td style="text-align: center;">  </td> <td style="padding-left: 10px;">V - Voltage</td> </tr> <tr> <td style="text-align: center;">  </td> <td style="text-align: center;">  </td> <td style="text-align: center;">  </td> <td style="padding-left: 10px;">A -Amps</td> </tr> <tr> <td style="text-align: center;">  </td> <td style="text-align: center;">  </td> <td style="text-align: center;">  </td> <td style="padding-left: 10px;">RPM – Default for 1800 RPM – to adjust motor see F_051</td> </tr> <tr> <td style="text-align: center;">  </td> <td style="text-align: center;">  </td> <td style="text-align: center;">  </td> <td style="padding-left: 10px;">Line speed – To establish ratio see F_007 and F_008</td> </tr> <tr> <td style="text-align: center;">  </td> <td style="text-align: center;">  </td> <td style="text-align: center;">  </td> <td style="padding-left: 10px;">Terminal Status Display – See Section B-4</td> </tr> </table>					Hz - Hertz's – Default				V - Voltage				A -Amps				RPM – Default for 1800 RPM – to adjust motor see F_051				Line speed – To establish ratio see F_007 and F_008				Terminal Status Display – See Section B-4
			Hz - Hertz's – Default																						
			V - Voltage																						
			A -Amps																						
			RPM – Default for 1800 RPM – to adjust motor see F_051																						
			Line speed – To establish ratio see F_007 and F_008																						
			Terminal Status Display – See Section B-4																						

### B-4 Terminal Status Display

Terminal status display allows users to verify the digital inputs as seen by the drive if the input is “open” or “closed” and will confirm the drives digital output status.

**Note:** This is an extremely valuable tool to confirm or troubleshooting wiring.

#### Terminal Status Display Description

Digital Input and Direction Terminals

FWD   REV   X5   X6

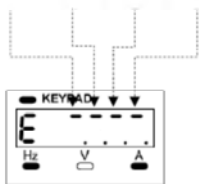

Digital Output Terminals

Ta2/Tc2   Y1   Y2   Ta1/Tb

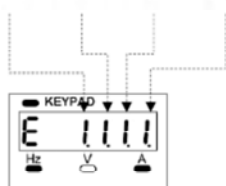

Digital Input Terminals

X3   X1   X2   X4

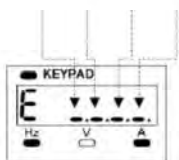

**Note:**

- Terminal Status Display displays the terminal signal status when a wire properly connects to the terminal.
- If a wire is properly connected to a terminal, the keypad display under Terminal Status Display shows “-” or “1” when the input or output terminal has a signal

## Section B Keypad Programming and Operation

### B-5 Examples of Parameter Programming

#### 1. Parameter Programming using the Digital Keypad

**Step 1:** Apply appropriate Power to L1, L2 and L3



**Note:** not all parameters can be adjusted during operation



(default display)

**Step 2:** Press  and the keypad displays (Starts **Program Mode**)







**Step 3:** Press  or  till the desired parameter is displayed



**Step 4:** Press  and the drive will show current value for this Parameter



**Note:** If the Parameter is not to be changed Press  or  to return to the Monitor mode.

**Step 5:** Press  or  Changes the value displayed (but not stored)



**Step 6:** Press  to save the program change and return to the monitor mode.



The drive is ready to “run” or “change” another parameter.

## Section B Keypad Programming and Operation

### Parameter programming sequence - Recap:

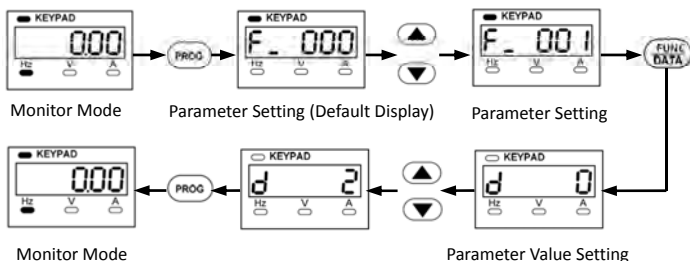

### 2. Programming Example Acceleration Change from 5 Sec to 15 Sec Set up / Change the Acceleration Time

In the monitor mode, the keypad displays:



**Step 1:** Press **PROG** and the keypad displays:



**Step 2:** Press **▲** to select the parameter F\_019 (Primary Acceleration Time)



(Primary Acceleration Time)

**Step 3:** Press **FUNC DATA** to enter the parameter value setting

**Step 4:** Press **▲** to change the value from "5" to "15"



(Acceleration Time Setting)

**Step 5:** To complete the acceleration time change, press **PROG** to save the change and return to the monitor mode.



## Section B Keypad Programming and Operation

### 3. Reset to Factory Setting

In the monitor mode – **Note: Drive cannot be operating when resetting**



**Step 1:** Press **PROG** to put the Drive in “Program” Mode



**Step 2:** Press **▲** or **▼** till the display shows F\_134



**Step 3:** Press **FUNC DATA** shows F\_134 current setting

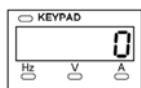

(Default Display)

**Step 4:** Press **▲** till “dEF\_60” is displayed to rest for 60HZ operation



(Default the factory setting 60Hz)

**Step 5:** Press **PROG** to reset all parameters back to the factory setting; the keypad displays “End” when the default the factory setting is completed and then return to the monitor mode automatically

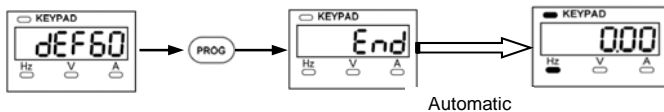

## Section B Keypad Programming and Operation

### 4. Upload the Program to the Keypad from the Drive

In the monitor mode, the keypad displays



**Step 1:** Press **PROG** to enter the parameter setting mode



**Step 2:** Press **▲** or **▼** to select the parameter F\_134 (Default Setting)



**Step 3:** Press **FUNC DATA** to show the Default Setting

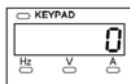

**Step 4:** Press **▲** to select "rd\_EE" (Read the parameter from the drive to the digital keypad)



(Read the parameter from the drive to the digital keypad)

**Step 5:** Press **PROG** to start the upload from the drive to the digital keypad. The keypad will display the running number from "CoPY.00" to "CoPY.97" and then displays "End" when the uploading process is completed.

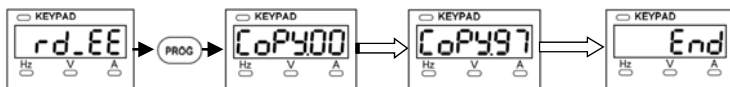

Auto-Counting

The keypad returns to the monitor mode automatically after the uploading process is completed.

## Section B Keypad Programming and Operation

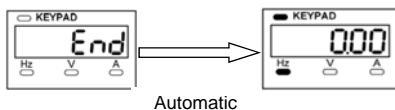

### 5. Download the program to the Drive from the Keypad

In the monitor mode, the keypad displays



**Step 1:** Press **PROG** to enter the parameter setting mode



**Step 2:** Press **▲** or **▼** to select the parameter F\_134



**Step 3:** Press **FUNC DATA** to show the Default Setting

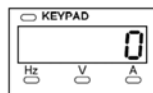

**Step 4:** Press **▲** to select "Wr\_EE" (Write the parameter from the digital keypad to the drive)



(Write the parameters from keypad to the drive)

**Step 5:** Press **PROG** to start downloading the program from the keypad to the drive. The keypad displays the running number from "CoPY.00" to "CoPY.97" and then displays "End" when the downloading process is completed

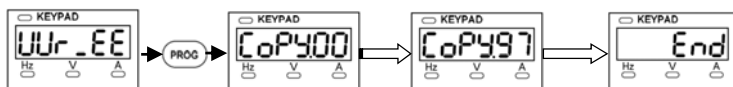

Auto-Counting

## Section B Keypad Programming and Operation

The keypad returns to the monitor mode after the downloading process is completed.

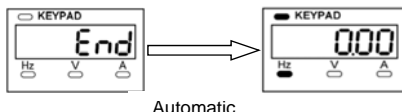

### 6. Clearing Faults

When the drive is tripped due to error or fault occurrence, the keypad displays the error trip message. Example: The drive is tripped to “Over Current – OC”, the keypad displays



To clear the faults:

**Step 1:** Press **STOP/RESET** to clear the fault message (Error Trip Message)

**Step 2:** Change the parameter setting and perform the troubleshooting in hardware or software (please refer to the section E – Troubleshooting)

**Step 3:** Complete the troubleshooting and re-start the operation by pressing **RUN**

### 7. Change the Display to RPM from the default HZ setting

In the monitor mode, the keypad displays





(Default Setting – Displaying the Drive Output Frequency to Motor)

To change the display from the frequency display to the motor speed (RPM):

**Step 1:** Press **PROG** to enter the parameter setting



## Section B Keypad Programming and Operation



**Step 2:** Press  or  to select the parameter F\_006 (Main Display Setting)

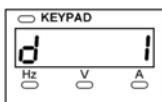

**Step 3:** Press  to enter the parameter value setting



(Default Setting: Display the Drive Output Frequency)

**Step 4:** Press  or  to select the value "6" (Display Motor Speed RPM)



**Step 5:** Press  to store the setting and return to the monitor mode

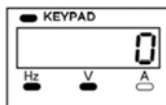

**Note:** the default motor is set for 4 Pole or 1800 RPM at 60HZ. If the motor is not a 4 pole (1800RPM) motor go to F\_051 using the same process to change the parameter to "2" (3600 RPM), "6" (1200 RPM) up to 10 poles.

To improve the accuracy of the display and if the information is known: Adjust F\_050 Motor Slip Compensation and F\_049 Motor No Load Amps.

**Step 6:** Press  to start the motor and now the keypad will display motor speed in RPM's.



## Section C Parameter Table

### C 1- Keypad Parameters that Change the Keypad Operation

Name	Descriptions	Range
	Software Version and drive information Software Version Drive Model Number Drive Running hours Drive "Power Applied" in Hours Software "Check Sum"	—
	<b>Start command</b>	<b>Rotation Command</b>
0:	Enables "FWD" and "REV" input terminals.	Close FWD or REV input for directions. If Both FWD and REV are "set", the drive will stop.
1:	FWD input enables drive but does not determine direction.	"Set" FWD input to enable drive. REV input "Set" for reverse.
2:		FWD and REV terminal determine directions. The drive stops when both FWD and REV are closed.
3:	Keypad RUN starts the drive	FWD and REV terminals are Inactive. Motor Rotates in <b>Only Forward Direction</b> .
4:		FWD and REV terminal are inactive. Motor Rotates in <b>Only Reverse Direction</b> .
		0~4
Name	Descriptions	Range
Speed	0: Speed is set by input analog terminal per function F_123. 1: Speed is set by keypad ( <b>display Frequency</b> ). 2: Speed is set by keypad ( <b>display RPM</b> ). 3: User Units setting from the keypad (Use F_007 and F_008). 4: Speed setting by momentary switches closer. See F_056, 57 and 58 to program inputs	0~4
STOP	0: STOP key disabled on Keypad. <b>WARNING:</b> Disabling Stop Button on Keypad should only be considered if no danger to operator and/or to machine. 1: STOP Key Enabled on the keypad.	0, 1
Keypad Control	0: The speed cannot be changed from the keypad. 1: Keypad can adjust speed.	0, 1
Speed Command Store	0: If F_004 is set to "0" the speed setting is not stored in the keypad. 1: If F_004 is set to "1" the speed setting will store after 3 minutes. Once the drive is restarted, it will return to the stored speed.	0, 1
Keypad Display	1: Output Frequency 2: Frequency that has been commanded.	1~8

## Section C Parameter Table

	3: Output Voltage. 4: DC Bus Voltage (Troubleshooting tool). 5: Output Current. 6: Motor Speed (default is 1800RPM motor - use F_051 change motor speed ). 7: Line Speed/User Units (Use F_007 and F_008 to define Ratio. 8: Terminal Status (Troubleshooting tool). See Section F-4.	
Units	When "Line Speed" or "User defined Units" are to be displayed on the Keypad (F_006), use the ratio to calibrate the display process speed.	0.00~500.00
Units nal	The display will show decimal values of F_007 up to three places	0~3

### C-2 Preset Speeds

Name	Descriptions				Range	U
	Jog Speed =±1	Preset 1 =±3	Preset 2 =±4	Preset 3 =±5		
Jog Speed	Set	-	-	-	0.00~400.00	0.0
Primary Speed	Off	Off	Off	Off		
Preset Speed 1	Off	Set	Off	Off		
Preset Speed 2	Off	Off	Set	Off		
Preset Speed 3	Off	Set	Set	Off		
Preset Speed 4	Off	Off	Off	Set		
Preset Speed 5	Off	Set	Off	Set		
Preset Speed 6	Off	Off	Set	Set		
Preset Speed 7	Off	Set	Set	Set		

**Note:**

**Parameter Value is Positive**

“Set” = Contact Closed

“Off” = Contact is Open

**If the parameter is negative (“-”) value**

“Set” = Contact Open

“Off” = Contact Closed.

**Jog Speed** - will override all other inputs

**Primary Speed** – is the speed set from keypad ordinarily or from Vin or lin (analog inputs)

**Note:** Shaded Parameters cannot be changed while the drive is running.

### C-3 Acceleration / Deceleration

Func	Name	Descriptions
F_018	Accel/Decel Base Freq	Determines how the drive calculates Acc/Dec rates.

## Section C Parameter Table

F_019	Primary Accel Time	Primary Accel time including preset speeds 4~7, and jog
F_020	Primary Decel Time	Primary Decel time including preset speeds 4~7, and jog
F_021	Accel Time – Preset 1	Acceleration time of preset speed 1.
F_022	Decel Time – Preset 1	Deceleration time of preset speed 1.
F_023	Accel Time – Preset 2	Acceleration time of preset speed 2.
F_024	Decel Time – Preset 2	Deceleration time of preset speed 2.
F_025	Accel Time – Preset 3	Acceleration time of preset speed 3.
F_026	Decel Time – Preset 3	Deceleration time of preset speed 3.
F_027	Secondary Accel Time	Secondary acceleration time when input terminal is “set” (F_052 –F_057; “2” or “-2”).
F_028	Secondary Decel Time	Secondary deceleration time when input terminal is “set” (F_052 –F_057; “2” or “-2”).
F_029	S-curve for Accel/Decel Time	S-curve acceleration and deceleration time at start and s

**Note:** Shaded Parameters cannot be changed while the drive is running.

## Section C Parameter Table

### C-4 Drive Output Parameters

Func	Name	Descriptions
F_031	Max Output Frequency	Max frequency for the drive. <b>Warning:</b> Do not set above safe operating speed for the motor machine as damage to the machine and possible injury may
F_032	Starting Frequency	Starting frequency of the V/HZ curve.
F_033	Starting Voltage	The starting voltage of the V/HZ curve.
F_034	Base Frequency	The base frequency for the V/F curve.
F_035	Motor Nameplate Voltage	This set the V/F ratio for proper motor operation
F_042	Max Freq (Upper Limit)	Used to define a different Max Freq based on F_031 (1.00 =
F_043	Starting Freq (Lower Limit)	Used to define a different Starting Freq F_033 (1.00 = Max o

**Note:** Shaded Parameters cannot be changed while the drive is running.

Func	Name	Descriptions
F_075	DC Braking Force	DC braking force (increases the braking force) <b>Warning:</b> Increasing braking force can increase heat in the motor and can cause motor machine damage.
F_076	DC Braking Time at "Stop"	DC braking time when the motor "Stops". <b>Warning:</b> Increasing time can increase heat in the motor and/or cause motor damage.
F_077	DC Braking Time at "Start"	DC Braking time at motor "Start"
F_132	DC Braking Frequency at "Stop"	Drive is commanded to "Stop" This determines the frequency Braking will begin
F_081	Switching Frequency	The higher the value = higher switching frequency.
F_082	Stop Mode	0: Ramp to stop 1: Coast to stop 2: Coast to stop + DC braking

## Section C Parameter Table

F_083	Reverse Lockout	0: Reverse rotation allowed 1: Reversal rotation NOT allowed
F_084	Skip Frequency 1	Frequency that drive will not operate to prevent Machine Vibration or Resonance
F_085	Skip Frequency 2	Frequency that drive will not operate to prevent Machine Vibration or Resonance
F_086	Skip Frequency 3	Frequency that drive will not operate to prevent Machine Vibration or Resonance
F_087	Skip Frequency Range	The frequency band above and below the skip frequency the drive will not operate to prevent Machine Vibration or Resonance

**Note:** Shaded Parameters cannot be changed while the drive is running.

## Section C Parameter Table

### C-5 Analog Input

Func	Name	Descriptions
F_040	<b>Vin</b> Gain	<b>Vin</b> analog input scaling corrects the max analog speed command max speed.
F_041	<b>Vin</b> Bias	<b>Vin</b> analog input to correct the min commanded speed to analog input.
F_047	Analog Input Filter	Increasing filtering time to smooth out the input signal by dampening the response (used with F_002=0).
F_107	Analog Input Dead Band	Use when there is a high signal to noise ratio on the input drive input. Use with F_047 when F_002 = "0".
F_123	Analog Input Source	0: <b>Vin+lin</b> 1: <b>Vin-lin</b> 2: <b>lin-Vin</b> 3: <b>Vin or lin</b> (select from X1~X6 terminals)
F_124	Analog Input ( <b>Vin</b> ) Option	0: Analog input gain 1: Frequency command
F_125	Analog Input ( <b>lin</b> ) Option	2: Current limit (Current can be viewed at F_133) 3: Output voltage adjustment of V/F pattern
F_126	<b>lin</b> Selection	Current Input "0" = 4~20mA "1" = 0~20mA
F_127	<b>lin</b> Gain	<b>lin</b> analog input scaling corrects the max analog speed command max speed
F_128	<b>lin</b> Bias	<b>lin</b> analog input to correct the minimum commanded speed to minimum analog input

**Note:** Shaded Parameters cannot be changed while the drive is running.

## Section C Parameter Table

### C-6 Analog Output

Func	Name	Descriptions
F_044	“Frequency Meter” <b>FM+</b> Analog Output Signal Selection(DC 0~10V)	0: Output frequency.            1: Speed command. 2: Output current.            3: <b>Vin</b> analog input speed 4: <b>Iin</b> analog input speed command.
F_045	<b>FM+</b> Analog Output Gain	Analog output ratio adjustment.
F_129	<b>AM+</b> Analog Output Signal Selection (DC 0~10V)	0: Output frequency.            1: Frequency command. 2: Output current. 3: <b>Vin</b> : analog input speed command (F_124 must be s 4: <b>Iin</b> : analog input speed command (F_125 must be s
F_130	<b>AM+</b> Analog Output Gain	Analog output ratio adjustment

### C-7 Motor Data and Protection

Func	Name	Descriptions
F_046	Motor Overload Protection Selections	0: Motor overload protection – Disabled. 1: Motor overload protection – Enabled. 2: Motor overload protection of separate cooling fans Ena <b>Warning:</b> Disabling should only be done if a separate over
F_048	Motor Rated Current	Current setting according to the motor Full Load Amps (F
F_049	Motor No-Load Current	Current setting per motor data or estimated by using 50% Load Amps (Amps).
F_050	Motor Slip Compensation	Correction for slip of the induction motor as the motor is l Improves the accuracy of the display RPM's.
F_051	Number of Motor Poles	Change the motor sync speed (used with F_006).

### C-8 Digital Inputs Note: Each input has 16 programmable inputs and one that is unique to a input terminal.

Func	Name	Descriptions
F_052	Input Terminal X1	<b>Unique Option for input</b> <b>X1</b> = 0 UP/DOWN command enter key
F_053	Input terminal X2	<b>Shared Input Options</b> ±1: Jog command. ±2: Switch between the seconda ±3: Preset 1. ±4: Preset 2. ±5: Preset 3. ±6: Drive “Reset” input. ±7: External fault input. ±8: Drive output disable. ±9: Coasting “Stop” (E-Stop).
F_054	Input terminal X3	<b>X3</b> = 0 Current limit enable ±10 Starting into a Spinning Load search. Search starts from M ±11: Starting into a Spinning Load

## Section C Parameter Table

F_055	Input terminal <b>X4</b>	<b>X4 = 0</b> Primary and secondary speed command select	search. Search starts from speed. ±12: Hold – when “Set” the ramp stopped, the speed maintain ±13: Speed “UP”. ±14: Speed “DOWN”. ±15: Reset UP/DOWN frequency HZ. ±16: Select analog input source
F_056	Input terminal <b>X5</b>	<b>X5 = 0</b> Stop command with 3-wire start/stop circuit	<b>Note:</b> Setting the option to “+” va “set” when input is made.
F_057	Input terminal <b>X6</b>	<b>X6 = 0</b> Stop command with 3-wire start/stop circuit	Setting the “-” value the input is s input is “open”.

**Note:** Shaded Parameters cannot be changed while the drive is running.

## Section C Parameter Table

### C-9 Digital Output

Func	Name	Descriptions
F_058	Output Terminal Y1	<b>Optional Settings for each Terminal</b> ±1: Motor power "on" (power to the motor AC or DC). ±2: Drive is "At" Commanded speed ±3: Zero speed. ±4 Drive run (AC output only)
F_059	Output Terminal Y2	
F_060	Relay Output Terminal <b>T1</b> Relay Output <b>Ta1, Tb1, Tc1</b> SPDT <b>Ta1</b> = N.O. <b>Tb1</b> = N.C. <b>Tc1</b> = Common	±5: Overload alarm. ±6: Overload detection. ±7: Low voltage detection. ±8: Braking detection. ±9: Alarm for restart after instantaneous power failure ±10: Alarm for restart after drive fault. ±11: Drive fault.
F_131	Relay Output Terminal <b>T2</b> Relay Output <b>Ta2</b> = N.O. <b>Tc2</b> = Common	<b>Note:</b> Setting the option to "+" value the input is "set" made. Setting the "-" value the input is set when the in "opened".
F_061	"At" Commanded Dead Band	Dead Band to prevent contact status change with load (Digital Output option "±2").
F_062	"Drive Run" Output Threshold Level	Output will not "set" till above this threshold (Output o
F_063	"Drive Run" Dead band	F_062 output dead band. The frequency above and b

**Note:** Shaded Parameters cannot be changed while the drive is running.

## Section C Parameter Table

### C -10 Miscellaneous

Func	Name	Descriptions
F_091	Fault Records	Display the last 5 records of faults.
F_092	Parameter Locking	0: Parameters are changeable, and Max. Freq. <b>cannot</b> exceed 120.0 Hz. 1: Parameters are locked, Max. Freq. <b>cannot</b> exceed 120.0 Hz. 2: Parameters are changeable, Max. Freq. <b>can</b> exceed 120.0 Hz. 3: Parameters are locked, Max. Freq. <b>can</b> exceed 120.0 Hz.
F_133	Current Limit Level	Monitoring the Drive current limit level as a % and F_0124 or F_125 when set to "2".
F_134	Default Setting Reset Clear Fault Log Upload Parameters to Keypad	dEF60: Reset to 60Hz default settings. dEF50: Reset to 50Hz default settings. SAv: Store setting. rES: Resume setting. rd-EE: Read parameter from drive to digital keypad.(WWE-201KP) Wr-EE: Write parameter from the digital keypad to

**Note:** Shaded Parameters cannot be changed while the drive is running.

### C-11 Function List

Function	Section	Actual Value	Default Value			
F_000	C-1		520	F_024	C-3	
F_001	C-1		3	F_025	C-3	
F_002	C-1		1	F_026	C-3	
F_003	C-1		1	F_027	C-3	
F_004	C-1		1	F_028	C-3	
F_005	C-1		1	F_029	C-3	
F_006	C-1		1			
F_007	C-1		20			
F_008	C-1		0			
F_009	C-2		60			
F_010	C-2		10			
F_011	C-2		20			
F_012	C-2		30			
F_013	C-2		0			
F_014	C-2		0			
Function	Section	Actual Value	Default Value			
F_015	C-2		0			
F_016	C-2		0			
F_017	C-2		6			
F_018	C-3		60			
F_019	C-3		5			
F_020	C-3		5			
F_021	C-3		5			
F_022	C-3		5			

## C-11 Function List

Function	Section	Actual Value	Default Value	C-8		4
F_030	C-4		0	F_054	C-8	1
F_031	C-4		60	F_055	C-8	2
F_032	C-4		0.5	F_056	C-8	7
F_033	C-4		230V:8.0 460V:12.0	F_057	C-8	6
F_034	C-4		60.00			
F_035	C-4		230V:230 460V:460			
F_036	Do Not Use					
F_037	Do Not Use					
F_038	Do Not Use					
F_039	Do Not Use					
F_040	C-5		1			
F_041	C-5		0			
F_042	C-4		1			
F_043	C-4		0			
Function	Section	Actual Value	Default Value			
F_044	C-6		0			
F_045	C-6		1			
F_046	C-7		1			
F_047	C-5		20			
F_048	C-7		Rated current of motor			
F_049	C-7		1/3 rated current of motor			
F_050	C-7		0			
F_051	C-7		4P			
F_052	C-8		3			

C-11 Function List

Function	Section	Actual Value	Default Value	Function	Section	Actual Value	Default Value
F_058	C-9		3	F_073	C-7		
F_059	C-9		2	F_074	C-7		
F_060	C-9		11	F_075	C-4		
F_061	C-9		2	F_076	C-4		
F_062	C-9		2	F_077	C-4		
F_063	C-9		0	F_078	C-4		
F_064	Reserved		1	F_079	C-4		23 46
F_065	C-7		0	F_080	C-4		
F_066	C-7		0	F_081	C-4		
F_067	C-7		0	F_082	C-4		
F_068	C-7		160	F_083	C-4		
F_069	C-7		0.1	F_084	C-4		
F_070	C-7		170	F_085	C-4		
F_071	C-7		160	F_086	C-4		
F_072	C-7		5				
<b>Function</b>	<b>Section</b>	<b>Actual Value</b>	<b>Default Value</b>	<b>Function</b>	<b>Section</b>	<b>Actual Value</b>	<b>Default Value</b>
F_087	C-4		0	F_096	C-4		0
F_088	C-4		150	F_097	C-4		0
F_089	C-4		0.5	F_098	C-7		1
F_090	C-4		100	F_099	C-10		1
F_091	C-10		no FE	F_100	C-10		2
F_092	C-10		0	<b>Function</b>	<b>Section</b>	<b>Actual Value</b>	<b>Default Value</b>
F_093	C-4		1	F_101	C-10		3
F_094	C-7		3	F_102	C-4		0

### C-11 Function List

F_103	C-4		3	F_127	C-5		1
F_104	C-4		5	F_128	C-5		0
F_105	C-4		5	<b>Function</b>	<b>Section</b>	<b>Actual Value</b>	<b>De</b>
F_106	C-4		0	F_129	C-6		2
F_107	C-5		0	F_130	C-6		1
F_108	C-8		10	F_131	C-9		1
F_109	Reserved		0	F_132	C-4		0
F_110	Do Not Use			F_133	C-10		M
F_111	Do Not Use			F_134	C-10		0
F_112	Do Not Use						
F_113	Do Not Use						
F_114	Do Not Use						
<b>Function</b>	<b>Section</b>	<b>Actual Value</b>	<b>Default Value</b>				
F_115	Do Not Use						
F_116	Do Not Use						
F_117	Do Not Use						
F_118	C-8		0				
F_119	C-8		0				
F_120	C-8		1				
F_121	C-8		0				
F_122	Do Not Use						
F_123	C-5		0				
F_124	C-5		1				
F_125	C-5		1				
F_126	C-5		0				

## Section D Parameter Description

### Parameter Index

Func	Name	Page	Func	Name	Page
F_000	Drive Info	48	F_045	FM+ Analog Output Gain	58
F_001	Start Command	48	F_046	Motor Overload Protection	59
F_002	Speed Input	49	F_047	Analog Input Filter	57
F_003	STOP	49	F_048	Motor Rated Current	59
F_004	Keypad Speed Control	50	F_049	Motor No-Load Current	59
F_005	Speed Comm. Auto Store	50	F_050	Motor Slip Compensation	59
F_006	Keypad Display	50	F_051	Number of Motor Poles	59
F_007	User Units	50	F_052	Input Terminal X1	59
F_008	User Unit Decimal	50	F_053	Input Terminal X2	59
F_009	Primary Speed	51	F_054	Input Terminal X3	59
F_010	Preset Speed 1	51	F_055	Input Terminal X4	59
F_011	Preset Speed 2	51	F_056	Input Terminal X5	59
F_012	Preset Speed 3	51	F_057	Input Terminal X6	59
F_013	Preset Speed 4	51	F_058	Output Terminal Y1	64
F_014	Preset Speed 5	51	F_059	Output Terminal Y2	64
F_015	Preset Speed 6	51	F_060	T1 Relay Output	64
F_016	Preset Speed 7	51	F_061	At Com. Dead Band	67
F_017	Jog Speed	51	F_062	Drive Run OP Thres. Lev.	67
F_018	Accel/Decel Base Freq.	52	F_063	Drive Run OP Dead Band	67
F_019	Primary Accel Time	52	F_075	DC Braking Force	54
F_020	Primary Decel Time	52	F_076	DC Braking Time at Stop	54
F_021	Accel Time – Preset 1	52	F_077	DC Braking Time at Start	54
F_022	Decel Time – Preset 1	52	F_081	Switching Frequency	55
F_023	Accel Time – Preset 2	52	F_082	Stop Mode	55
F_024	Decel Time – Preset 2	52	F_083	Reverse Lockout	55
F_025	Accel Time – Preset 3	52	F_084	Skip Frequency 1	55
F_026	Decel Time – Preset 3	52	F_085	Skip Frequency 2	55
F_027	Secondary Accel Time	52	F_086	Skip Frequency 3	55
F_028	Secondary Decel Time	52	F_087	Skip Frequency Range	55
F_029	S-curve for Acc/Dec Time	53	F_091	Fault Records	67
F_031	Max Output Frequency	53	F_092	Parameter Locking	67
F_032	Starting Frequency	53	F_107	Analog Input Dead Band	57
F_033	Starting Voltage	53	F_127	Iin Gain	56
F_034	Base Frequency	53	F_128	Iin Bias	57
F_035	Motor Nameplate Voltage	53	F_129	AM+ Analog Output Sig.	58
F_040	Vin Gain	56	F_130	AM+ Analog Output Gain	58
F_041	Vin Bias	57	F_131	T2 Relay Output	64
F_042	Max Frequency	53	F_132	DC Braking Freq. at Stop	54
F_043	Starting Frequency	53	F_133	Current Limit Level	68
F_044	FM+ Analog Output Sig.	58	F_134	Default Setting	68

## Section D Parameter Description

### D-1 Keypad

**F\_000: Drive Information** – this is a “view” only parameter



Hz <input type="radio"/>	V <input type="radio"/>	A <input type="radio"/>	Software Version
Hz <input checked="" type="radio"/>	V <input type="radio"/>	A <input type="radio"/>	Drive Model Number
Hz <input type="radio"/>	V <input checked="" type="radio"/>	A <input type="radio"/>	Drive Running Hours
Hz <input checked="" type="radio"/>	V <input checked="" type="radio"/>	A <input type="radio"/>	Drive Power Applied in Hours
Hz <input type="radio"/>	V <input type="radio"/>	A <input checked="" type="radio"/>	Software Checksum
Hz <input checked="" type="radio"/>	V <input type="radio"/>	A <input checked="" type="radio"/>	Reserved

Using the  or  key can switch displays. The three LEDs below the display labeled “HZ”, “V” and “A” are used to confirm what is being displayed. See chart above.

**F\_001: Start Command** has 5 modes

**= 0** Terminal **FWD** and **REV** are active. Closing either input determines direction. If both inputs are “open” or both inputs “closed” drive turns “off”.

**=1** Terminal **FWD** and **REV** are active. The **FWD** terminal acts as the “enable”; with direction from the **REV** terminal.

**FWD** open drive stops so **REV** is irrelevant

**FWD** closed drive “enabled” so **REV** will determine direction

**REV** Open – Drive operates in the forward direction until **FWD** opens

**REV** Closed – Drive operates in the reverse direction until **FWD** opens

**=2** Terminal **FWD** and **REV** are active. Start control by the keypad “RUN”. Closing the **FWD** or **REV** input determines direction but does not start the drive. If both inputs are open or both inputs closed drive turns “off”.

**=3** Terminal **FWD** and **REV** are inactive.

Start control by the keypad “RUN” key; operation in forward direction only.

**=4** Terminal **FWD** and **REV** are inactive.

Start control by the keypad “RUN” key; operation in reverse direction only.

**Note:** If the display the most left digit shows “-” the drive is in Reverse direction

**Note:** When F\_001=0 or 2, If both inputs are open drive turns “off”, the display

## Section D Parameter Description

(when in the monitor mode) will flash "-----". If both drive inputs are closed, the keypad will display (when in the monitor mode) "  F ".

**F\_002: Speed Input** selection has 5 modes

=0 Frequency is controlled by the analog input terminal (**Vin** or **lin** analog input (F\_123 selects the source).

**Vin-GND:** Input terminal range DC 0~10V. Adjust the drive to the input by parameter F\_040 and F\_041. See Section A-3

**lin-GND:** Input terminals selecting the input mode via SW1.

SW1→**I** mode factory setting: Input current source range 4~20mA or 0~20mA (selecting by F\_126).

SW1→**V** mode: Input voltage sources range: 2~10V or 0~10V (selecting by F\_126).





Calibrate the drive to the input signal use by parameter F\_127 and F\_128.

=1 Frequency (speed) is set from the keypad.

=2 RPM is set by the keypad.

=3 Line Speed or User Units is set by the keypad. See F\_007 and 008 to calibrate motor speed to display.

=4 Speed is set by UP/DOWN input terminal. See C-8

**Note:** When F\_002=1~3, press the  or  key in the monitoring mode, the frequency setting will blink, but not changed. Press the key  or  again; then the frequency setting can be changed. Save the setting by hitting "Func/Data" if power is lost it will return to saved speed when power returns and "Run" pushed

**F\_003 Keypad "STOP"**

=0 The Keypad "STOP" is **disabled**. **Warning:** Disabling "STOP" should only be considered is there is no danger to operator and/or machine.

=1 The Keypad "STOP" is **enabled**

**Note:** The using the "STOP" key.



"STOP" key for Emergency Stop: When the drive start command is via the input terminal (F\_001=0 or 1) and the "STOP" key is pressed during drive's operation, the output frequency will ramp to 0.00Hz. The keypad will show . To restart the drive, "open" the

## Section D Parameter Description

---

input between the terminals **FWD** and **REV**.

**Note:** using the “STOP” key for normal stop:

When F\_001=2 or 3, the start is controlled by the keypad  key and the stop is controlled by  key.

### **F\_004 Speed Control from the keypad**

=0 The keypad cannot change speed

=1 The keypad can change speed

### **F\_005 Speed Command Auto Store**

=0 Keypad the frequency setting will not be saved automatically after 3 minutes of operating at the same speed.

=1 If **F\_004** is set “=1”, the frequency setting will be saved after 3 minutes automatically of operating at the same speed. If power is lost and then restored when the “Run” command is given, the drive will return to the saved speed.

### **F\_006 Keypad Display** has 8 modes to display drive information

=1 Output Frequency – Shows the current output frequency

=2 Frequency Setting – Frequency that has been commanded

=3 Output Voltage

=4 DC Bus Voltage

=5 Output Current

=6 Motor Speed (RPM) based on 1800RPM motor See F\_051 to change

=7 Line Speed/User units (customized display units).

See F\_007 and F\_008 to calibrate the display so operator can set speed based on production or flow rate.

=8 Terminals Status - troubleshooting tool for inputs and outputs wiring. See Section F-4 to see the status of each input or output.

### **F\_007: User Units (Machine speed ratio)** for when using F\_006 = 7

Machine speed = machine speed ratio (F\_007) x output frequency

### **F\_008: User Units Decimals (Digits displayed)** when F\_006 =7

Line speed or “user units” can be shown with up to three decimal place resolution (0.000).

## Section D Parameter Description

**D-2 Preset Speeds** – Using the multi function inputs F\_052 – F\_057 and input terminals defined as =3,4,5 up to 7, speeds can be defined by a contact closure or a combination of contact closures. Preset Speeds 1 and 3 have their own Accel and Decel per parameter F\_018 – F\_025 see D-3. Preset speeds 2, 4, 5, 6 and 7 use Accel and Decel rates F\_019 and F\_020.

**Note:** In F\_052 and F\_057, the preset modes have two options. If functions are programmed to “+” 3,4 or 5 value, the input is “set” on contact closure. If functions are programmed to a “-” value, the input is set when the contact “opens”.

- F\_009 Primary Speed (range 0.00~400.00Hz)**
- F\_010 Preset Speed 1 (range 0.00~400.00Hz)**
- F\_011 Preset Speed 2 (range 0.00~400.00Hz)**
- F\_012 Preset Speed 3 (range 0.00~400.00Hz)**
- F\_013 Preset Speed 4 (range 0.00~400.00Hz)**
- F\_014 Preset Speed 5 (range 0.00~400.00Hz)**
- F\_015 Preset Speed 6 (range 0.00~400.00Hz)**
- F\_016 Preset Speed 7 (range 0.00~400.00Hz)**
- F\_017 Jog Speed (range 0.00~400.00Hz)** overrides other preset speeds. Jog Accel and Decel is defined by F\_019 and F\_020.

**Note:** Max Speed is limited to maximum speed parameter F\_031

Switch Combination for Preset Speeds Input Terminals (see F_052 thru F_057)					
Jog =±1	Preset 1 =±3	Preset 2 =±4	Preset 3 =±5	Commanded Speed	Parameter To set Speed
Set	-	-	-	Jog speed	F_017
OFF	OFF	OFF	OFF	Primary Speed	F_009
OFF	Set	OFF	OFF	Preset speed 1	F_010
OFF	OFF	Set	OFF	Preset speed 2	F_011
OFF	Set	Set	OFF	Preset speed 3	F_012
OFF	OFF	OFF	Set	Preset speed 4	F_013
OFF	Set	OFF	Set	Preset speed 5	F_014
OFF	OFF	Set	Set	Preset speed 6	F_015
OFF	Set	Set	Set	Preset speed 7	F_016

**“Set” = contact closed, and “Off” = Contact open: Mode is a positive value**

**“Set” = contact open and “Off” = Contact closed: Mode is a “-” value.**

**Jog Speed** - will override all other inputs.

**Primary Speed** – is the speed with no inputs “set”

**Note:** Multi-speed and acceleration/deceleration time

## Section D Parameter Description

---

- ※ When F\_001 = 1 and the drive is at stop, the jog command is set, and the motor will be started with the jog speed since the jog command also has “Start” function when F\_001 = 1.
- ※ Under the preset speed (primary speed excluded), analog input terminals (**Vin**, **lin**) are disabled.
- ※ Primary speed can be **Vin** or **lin** if F\_124 (**Vin**) = 1 (primary speed controlled by POT) or when F\_125 (**lin**) = 1 (primary speed controlled by current source input).

### D-3 Acceleration and Deceleration

#### F\_018 Accel/Decel Base Frequency (range 0.01~400.00Hz)

This defines the rate of acceleration. The default frequency is 60HZ. If the acceleration time is set to 10 seconds, an output of 60HZ is achieved in 10 seconds. If the motor is commanded to 30HZ the acceleration time will be in 5 seconds.

#### F\_019 Primary Acceleration Time (range 0.0~3200.0 secs)

#### F\_020 Primary Deceleration Time (range 0.0~3200.0 secs)

#### F\_021 Acceleration Time – Preset 1 (range 0.0~3200.0 secs)

#### F\_022 Deceleration Time – Preset 1 (range 0.0~3200.0 secs)

#### F\_023 Acceleration Time – Preset 2 (range 0.0~3200.0 secs)

#### F\_024 Deceleration Time – Preset 2 (range 0.0~3200.0 secs)

#### F\_025 Acceleration Time – Preset 3 (range 0.0~3200.0 secs)

#### F\_026 Deceleration Time – Preset 3 (range 0.0~3200.0 secs)

**Note:** Preset Accel and Decel rates are based on the time to go from 0 output to Reference Frequency set in F\_018

**Note:** Preset Speeds 4-7 and Jog speed use the Primary Accel/Decel setting

#### Secondary Accel/Decel rates for Inputs F\_052 – F\_057 if set to $\pm 2$ .

By “Setting” the Secondary Accel/Decel Input a different set of Accel/Decel rates.

#### F\_027 Secondary acceleration time (range 0.0~3200.0 secs)

#### F\_028 Secondary deceleration time (range 0.0~3200.0 secs)

**S-Curve Accel/Decel** – provides a softer to achieve faster accel/decel but preventing loads from toppling or loads that are being pulled from breaking.

## Section D Parameter Description

### F\_029 S-Curve for the Accel/Decel Time (range 0.0~3200.0 secs)

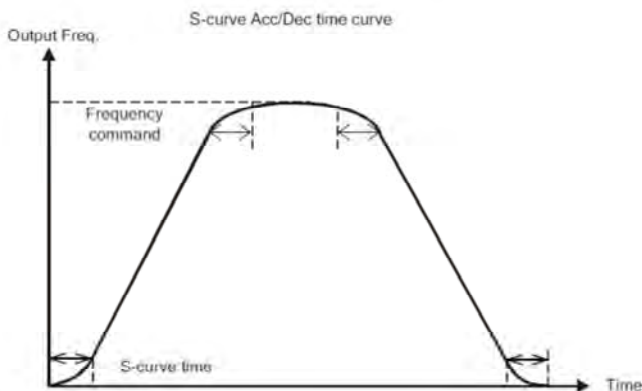

#### D-4 Drive Output / Parameters

##### F\_031 Maximum Output Frequency (range 0.1~400.0Hz)

**Warning:** Do not set above safe operating speed for the motor or machine as damage to the machine and possible injury may result.

##### F\_032 Starting Frequency (range 0.1~10.0Hz)

This is the starting frequency, the drive will output at start to insure enough torque to start the load.

##### F\_033 Starting Voltage

This is the starting voltage, the drive will output at start to insure enough torque to start the load. Increasing this setting can create heat in the motor.

##### F\_034 Base Frequency (range 0.1~400.0Hz)

Motor base frequency (nameplate frequency)

##### F\_035 Motor Nameplate Voltage

##### F\_042 Maximum Frequency (Frequency Upper Limit)

Drive output frequency will be limited to this set point.

##### F\_043 Starting Frequency (Frequency Lower Limit)

The drive is starting frequency to the motor and its lower limit.

Frequency upper limit =  $F_{042} \times F_{031}$  (Max Output Frequency)

Frequency lower limit =  $F_{043} \times F_{031}$  (Max Output Frequency)



**DC Braking** is not a substitute for a holding brake but will create a braking force to the load to stop a load that is moving (wind milling fan) before “start” or help bring a load to faster stop. **Warning:** This force can be set high enough to break the motor shaft or connected machine.

**F\_075 DC Braking Force (0~150% of drive rated current)**

This function is to set the current level of the DC braking force. **Warning:** Increasing the braking force can create excessive heat in the motor and can cause motor and/or machine damage.

**F\_076 DC Braking Time at “Stop” (0.0~20.0 seconds)**

**Warning:** Increasing the braking time can create heat in the motor and can cause motor damage.

**F\_077 DC Braking Time at “Start” (0.0~20.0 seconds)**

**F\_132 DC Braking Frequency at “Stop”.** This is the frequency that braking will begin.

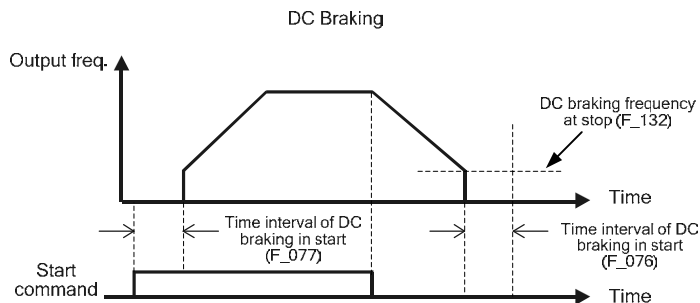

※ If the frequency command is set below F\_032 (starting frequency) during the operation, DC braking will be enabled when the output frequency is dropped below the start frequency F\_132 function is ineffective.

**F\_081 Switching frequency (0~6)**

Increasing the switching frequency will increase heating of the output transistors.

## Section D Parameter Description

Mode	0	1	2	3	4	5	6
Switching Frequency	800Hz	2.5kHz	5kHz	7.5kHz	10kHz	12.5kHz	15kHz

Setting the proper switching frequency must consider the motor cable length (see section OV-9: Switching Frequency Versus Cable Length).

### F\_082 Stop Mode

- =0 Ramp to stop
- =1 Coast to stop
- =2 Coast to stop + DC braking

When F\_082=2, the operation characteristics are as shown in figures below:

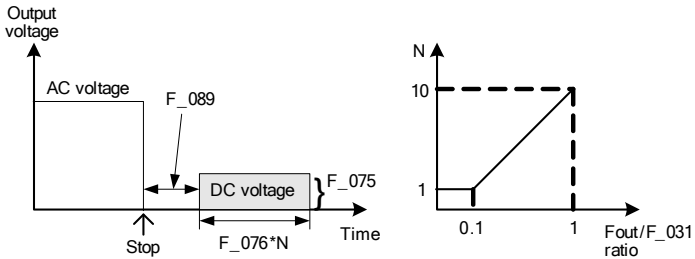

### F\_083 Reverse Lockout

- =0 Reverse rotation allowed
- =1 Reverse rotation NOT allowed

### F\_084 Skip Frequency 1 (0.0~400.0Hz)

### F\_085 Skip Frequency 2 (0.0~400.0Hz)

### F\_086 Skip Frequency 3 (0.0~400.0Hz)

### F\_087 Skip Frequency Range of Skip Frequency 1, 2, 3 (0.0~25.5Hz)

In order to avoid the mechanical resonance, these parameters prevent the drive from operating at system resonant frequencies.

There are three skip frequencies and one skip frequency interval.

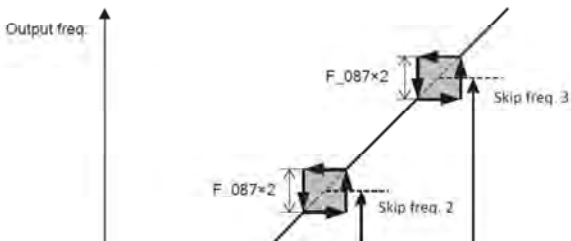

### D-5 Analog Input

**F\_040 Vin Gain (range 0.00~2.00)**

**F\_127 Iin Gain (range 0.00~2.00)**

- a. Analog input terminal:
  - Vin** → GND 0~10V
  - Iin** → GND 4~20mA (2~10V) or 0~20mA (0~10V)
- b. Maximum freq. setting =  
Maximum output freq. (F\_031) x analog input gain (F\_040 or F\_127)

For example: if analog input bias = 0.00

Maximum output freq. 60.0Hz  
Analog input gain = 1.20

Maximum output freq. 60.0Hz  
Analog input gain = 0.80

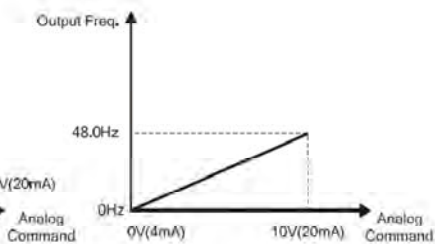
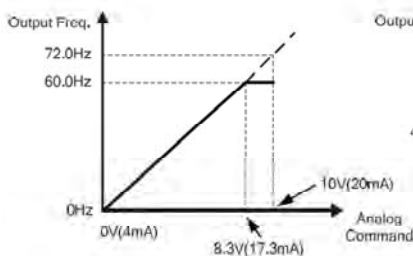

**F\_041 Vin Bias (range -1.00~1.00)**

**F\_128 Iin Bias (range -1.00~1.00)**

Bias frequency =

Maximum output freq. (F\_031) X analog input bias (F\_041 or F\_128)

For example: if analog input gain = 1.00

Maximum output freq. 60.0Hz  
Analog input bias = 0.05

Maximum output freq. 60.0Hz  
Analog input bias = -0.05

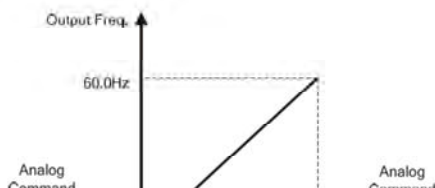
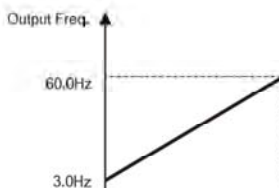

$$\text{Freq. Command} = \frac{(\text{Max. freq. setting} - \text{Bias freq.})}{10\text{V}(20\text{mA})} \times \text{analog command} + \text{freq. bias}$$

a. Example of reverse control application

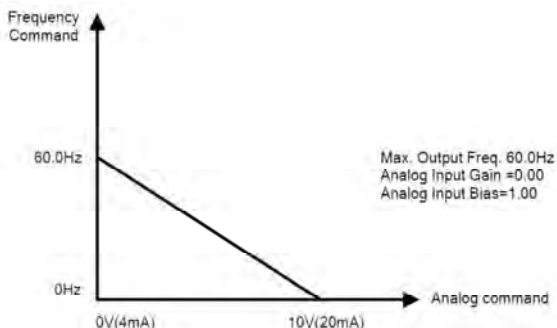

### **F\_047 Filter time of analog input (setting range 0 ~ 255)**

Filtering will reduce the effect of electrical noise on the input for frequency command (F\_002=0). A larger setting results in slower response. The setting value =0 is mean No filtering.

### **F\_107 Analog frequency dead zone (setting range 0.00 ~ 2.55)**

When the input has small variations in the signal, this setting can be used to stabilize the motor speed by increasing the dead band. This setting must be applied along with the F\_047.

### **D-6 Analog Output**

#### **F\_044 FM+ analog output signal selection**

#### **F\_129 AM+ analog output signal selection**

The analog output signal is DC 0~10V

0: Output frequency (only output under drive operation)

1: Frequency command (output at drive operation and stop)

2: Output current

3: Vin frequency setting

(output at drive operation and stop, enable at F\_124=1)

4: lin frequency setting

(output at drive operation and stop, enable at F\_125=1)

### F\_045 FM+ analog output gain (range 0.00~2.00)

### F\_130 AM+ analog output gain (range 0.00~2.00)

Analog output terminals are **FM+ – M-**, **AM+ – M-** (At 1/2 HP~5HP analog output terminals are **FM+ – GND**, **AM+ – GND**)

The kinds of analog output signal is defined by F\_044 and F\_129

$$\text{Analog output gain} = \frac{\text{Maximum output freq.}}{\text{Output freq. (freq. command)}} \quad \text{or} \quad \frac{\text{Drive rated current}}{\text{Output current}}$$

Analog output curve

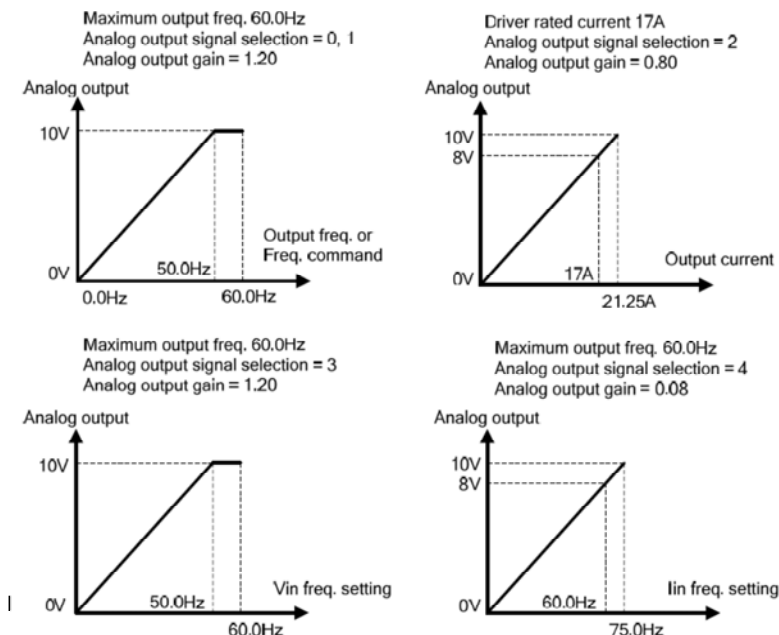

### F\_046 Motor Overload Protection Selections (OL)

- 0 : Motor overload protection: Disabled
- 1 : Motor overload protection: Enabled
- 2 : Motor overload protection of the independent cooling fans

### F\_048 Motor Rated Current (range 10 to 150% of drive rated current )

### F\_049 Motor No-Load Current (range 0 to motor rated current (F\_048))

### F\_050 Motor Slip Compensation (range -9.9 to 10.0Hz)

Motor slips in terms changes with motor loading, the slip compensation corrects the motor RPM display. The compensation formula is as

## Section D Parameter Description

---

follows

Freq. compensation =

$$\frac{\text{Loading current} - \text{non-load current (F\_049)}}{\text{Rated current (F\_048)} - \text{non-load current (F\_049)}} \times \text{slip compensation (F\_050)}$$

**F\_051 Motor Poles (2, 4, 6, 8, 10)**

$$\text{Motor speed (RPM)} = \frac{120}{\text{Motor poles number (F\_051)}} \times \text{output frequency}$$

### D-8 Digital Inputs

**F\_052 Input Terminal X1**

**F\_053 Input Terminal X2**

**F\_054 Input Terminal X3**

**F\_055 Input Terminal X4**

**F\_056 Input Terminal X5**

**F\_057 Input Terminal X6**

- '+' represents positive logic (normal open)
- '-' represents negative logic (normal close)
- Multi-function terminals X1~X6 can be set to perform any of the following functions:

**±1** Jog command (refer to F\_017)

**±2** Switch between the secondary accel/decel (refer to F\_027, F\_028)

**±3** Preset 1 (refer to F\_010~F\_016)

**±4** Preset 2 (refer to F\_010~F\_016)

**±5** Preset 3 (refer to F\_010~F\_016)

**±6** Drive "Reset" input - When the drive trips, "Setting" this input resets the drive so it can be restarted.

**±7** External fault input – When this input is "Set", the drive will fault turning off the drive output. **Note:** This function does not work when the drive is off.

**±8** Drive output disable – when this input is "set", the drive output is disabled or turned "off". Once the input is "Released", the drive output will ramp up the voltage. **Note:** the frequency remains as commanded.

## Section D Parameter Description

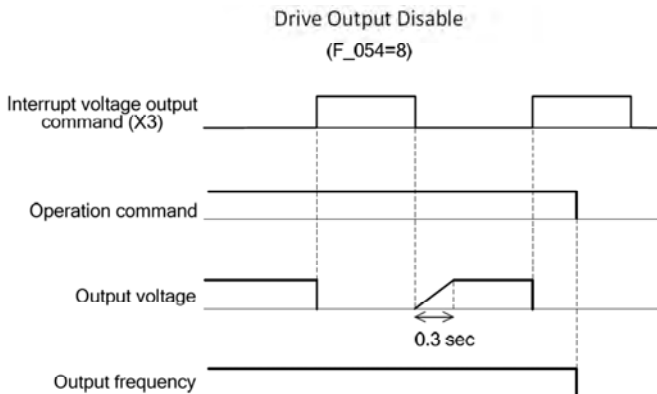

**±9** Coasting "Stop" (E-Stop) –when the input is "Set", the drive output is disabled. The drive will ramp to the command speed when the input is "released".

**±10** Drive to Sync to a motor speed starts at Max Frequency – if the input is "set" when the drive starts, the output will go to the max frequency and start the speed search. This input is used when the load is expected to be rotating WHEN the start command is given.

**±11** Drive to Sync to a motor speed starts at Commanded speed – If the input is "Set" when the drive starts the output will go to commanded speed and start the speed search. This input is used when the load is expected to be rotating WHEN the start command is given.

**±12** Holding command

Motor is running at a constant speed without being affected by accel/decel or speed command.

**±13** Speed "UP" (frequency setting stepping increase)

**±14** Speed "DOWN" (frequency setting stepping decrease)

**±15** Reset UP/DOWN frequency setting to 0.00Hz (frequency command erase to 0.00Hz) Illustrated as follows:

## Section D Parameter Description

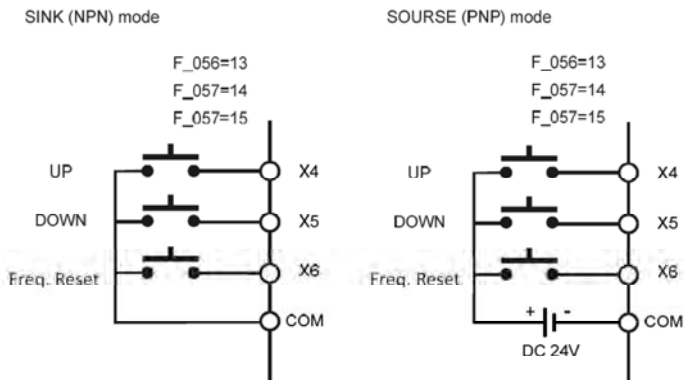

Example: Speed UP/DOWN and RESET by External Switch Controls

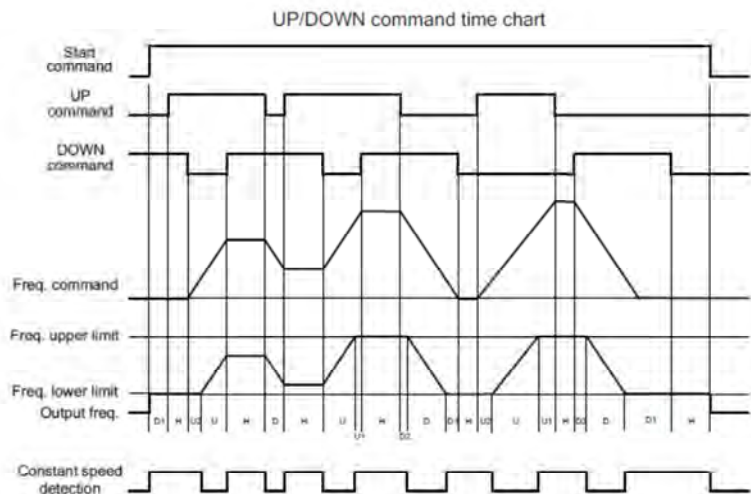

H=HOLD (stall) status

U1=UP status bounded at the upper limit of the frequency

U2=UP status bounded at the lower limit of the frequency

D1=DOWN status bounded at the lower limit of the frequency

D2=DOWN status bounded at the upper limit of the frequency

**±16** Select analog input source (F\_123 = 3 (Vin or lin))

## Section D Parameter Description

Setting value is 16	Contact a, Vin input terminal as the analog input source
	Contact b, lin input terminal as the analog input source
Setting value is -16	Contact a, lin input terminal as the analog input source
	Contact b, Vin input terminal as the analog input source

**F\_052~F\_057 = 0, the functions are described as follows:**

### F\_052 Setting input terminal X1

Confirm key of the UP/DOWN frequency setting.

**X1** and **COM** disconnected → UP/DOWN command can adjust the frequency setting, but the output frequency is not changed and follows the frequency setting.

**X1** and **COM** connected → the output frequency starts to accelerate or decelerate until reaching the frequency setting.

### F\_053 Setting input terminal X2

DC braking enabled command (when drive stops).

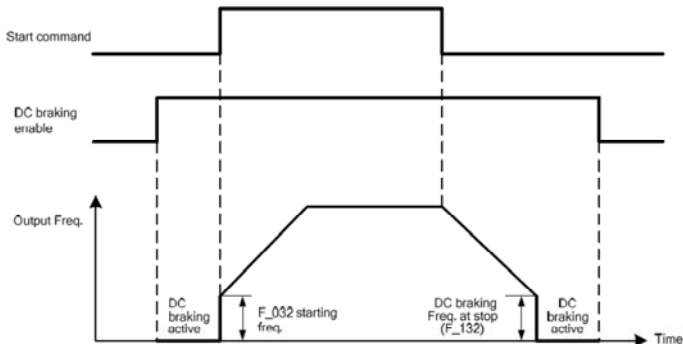

... 1g enabled.

2. At the DC braking enabled: the output current is set by the F\_075 setting value.
3. At the start or jog command is enabled, the DC braking is disabled and motor starts running until reaches the commanded frequency.
4. At the start or jog command disabled, the output frequency will be decelerate to the DC braking frequency level, DC braking active.

### F\_054 Setting input terminal X3

## Section D Parameter Description

Current limit enabled

F\_133: Setting the current limit

Using the keypad:

- X3** and **COM** connected, either F\_124 or F\_125 is setting 2, the current limit enabled. The current limit level monitoring by F\_133 (range 1~150).
- X3** and **COM** disconnected, the current limit disabled. The current limit level F\_133 monitoring level shall be identical with F\_071 (range 30~200).

For example: F\_054=0, X3 and **COM** connected, F\_124=2, F\_125=1 (Input Vin 0~10V corresponding to drive rated current 1~150%)

### F\_055 Setting input terminal X4

Primary and secondary frequency command selection

When **X4** and **COM** connected is the secondary frequency command, **X4** and **COM** disconnected is the primary frequency command)

F\_002: primary frequency command selection

F\_122: secondary frequency command selection

### F\_056 Setting input terminal X5

### F\_057 Setting input terminal X6

Stop command with 3-wire start/stop circuit setting

**X5**: contact a

**X6**: contact b

SINK (NPN) mode

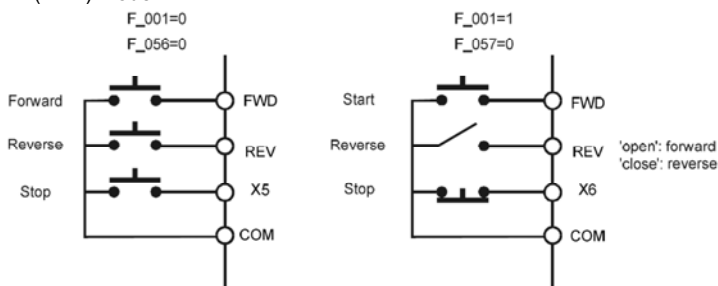

Example: 3-Wire Start/Stop Terminal Connection

SOURCE (PNP) mode

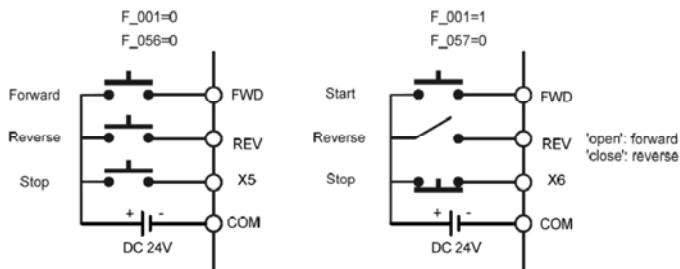

Example: 3-Wire Start/Stop Terminal Connection

### D-9 Digital Outputs

**F\_058** Output Terminal Y1

**F\_059** Output Terminal Y2

**F\_060** Relay Output Terminal Ta1 and Tb1

**F\_131** Relay Output Terminal Ta2 and Tc2

Y1 and Y2 are open-collector output terminals. The maximum output specification is below DC48V / 50mA.

Ta1, Ta2 (normal open) and Tb1 (normal close) are relay output terminals. The maximum output specification is AC 250V / 0.5A  $\cos\theta=0.3$ .

### General Operation for outputs

‘+’ represents positive logic (normal open)

‘-’ represents negative logic (normal close)

Output terminal Y1, Y2, Ta1, Ta2, and Tb1 can be set as one of below functions:

**0** Disable (no function operated at terminals)

**±1** Motor power “on”  
Detect at drive start.

**±2** Reached “At Commanded speed”

## Section D Parameter Description

Reach At Setting Speed (F\_058=2)

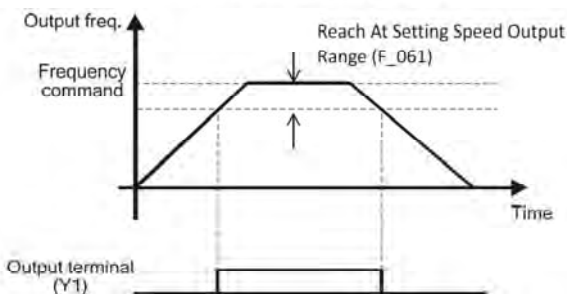

**±3** Zero speed

Detect at drive zero speed and no detect during the DC braking.

**±4** Drive run output

Drive Run Output (F\_059=4)

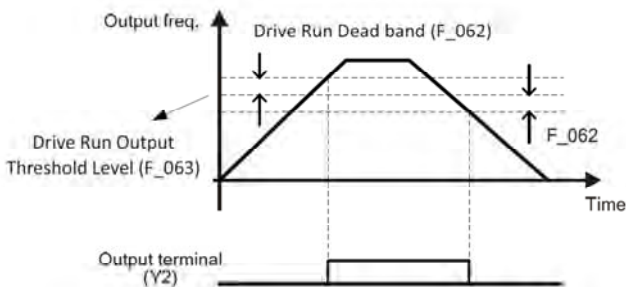

**±5** Overload alarm

**±6** Overload detection – Drive will lower the speed (frequency) to try and reduce load to prevent tripping of the drive.

**±7** Low voltage detection

Low voltage detection (F\_058=7)



## Section D Parameter Description

### ±8 Braking detection

Detect at drive P, N voltage that is greater than dynamic brake voltage.

### ±9: Restart after the instantaneous power failure detection

Enable when F\_078 set value is 1.

Restart after the instantaneous power failure detection  
(F\_058=9)

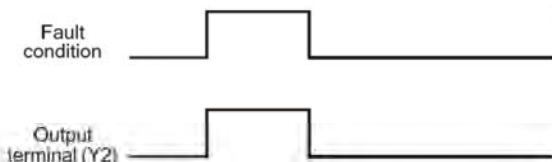
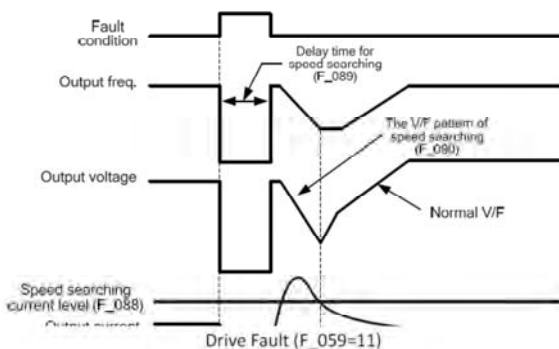
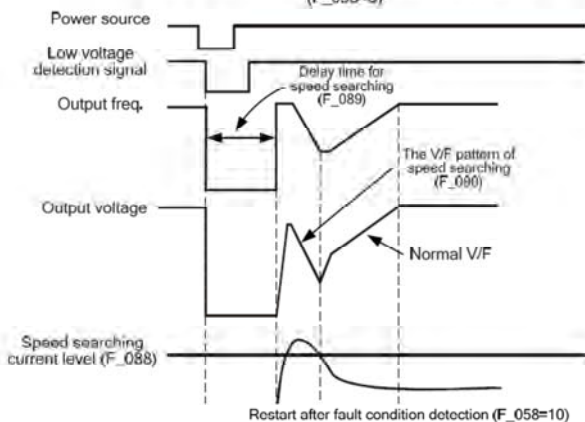



**F\_061 “At” Commanded Dead Band (range 0.0 ~10.0Hz)**

**F\_062 Drive Run Output Threshold Level (range 0.0 ~10.0Hz)**

**F\_063 Drive Run Dead Band (range 0.0~400.0Hz)**

### D-10 Miscellaneous

#### F\_091 Fault Records (view only)

Displaying five fault records, entry data first display is the latest fault record, press  and  key can be select other fault records.

#### F\_092 Parameter Locking

0: Parameters are changeable, Max. freq. cannot exceed 120.0 Hz

1: Parameters are locked, Max. freq. cannot exceed 120.0 Hz

2: Parameters are changeable, Max. freq. can exceed 120.0 Hz

3: Parameters are locked, Max. freq. can exceed 120.0 Hz

#### F\_133 Current Limit Level

**X3** and **COM** disconnected, the current limit disabled. The current limit level F\_133 monitoring level shall be identical with F\_071 (range 30~200).

#### F\_134 Default Setting

Drive general parameters are to reset all user settings back to the original factory setting as well as to store and resume all user settings (the last setting parameter).

The parameter setting functions of F\_134 are illustrated as follows:

**0** : Reserved

**CLF** : Clear fault records

**dEF60** : Restore the factory settings of 60Hz

**dEF50** : Restore the factory settings of 50Hz

**SAU** : Save settings – Parameters have been saved to keypad.

**rES** : Restore previous settings

**rd\_EE** : Upload parameters to the keypad

**UUr\_EE** : Write the parameter from the keypad to the drive.

## Section D Parameter Description

---

**Note:** The codes `rd_EE` and `UUr_EE` are copy function to be used for the case of several drive with the same setting.

## Section E Terminal Wiring Connection for Operation

This Section contains common control modes. Each section includes wiring and programming steps.

### E-1 Keypad Speed Control – with Forward and Reverse

The keypad control and optional external control wiring - the “FWD” and “REV” terminals can be used to determine motor direction

**Keypad Control Wire Connection Diagram**

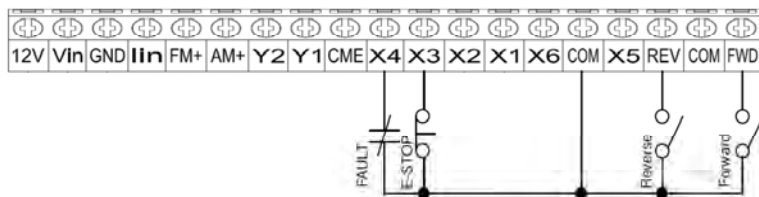

**Terminal and Function Setup Table**

Function	Value	Drive Terminal	Descriptions
F_001	2	FWD	<b>START:</b> Press “RUN” with the <b>Forward</b> contact Closed and the <b>Reverse</b> Open <b>STOP:</b> “Forward” and “Reverse” contacts are Open, the motor Stops
		REV	<b>START:</b> Press “RUN” with the <b>Reverse</b> contact Closed and the <b>Forward</b> Open <b>STOP:</b> “Reverse” and “Forward” are open motor Stops
F_002	1	Vin	Speed input by the keypad
F_054 (Optional)	-9	X3	E-Stop contact is “Opened”, the motor coasts to stop and the drive displays “Fr
F_055 (Optional)	-7	X4	If the External Relay Opens, the drive trips to “thr” and motor stops. The contact must be reset and the drive must be reset.
<b>Note:</b>			
1. If both FWD and REV terminals are set at the same time, the motor stops and the drive displays “ <b>dtF</b> ” ( <b>direction command error</b> ). If both FWD and REV terminals are open at the same time, the motor stops and the drive displays “- - - - -” ( <b>no direction command input</b> ).			

## Section E Terminal Wiring Connection for Operation

2. To Stop the motor, use the keypad “**STOP/RESET**” button or by opening “**Forward**” or “**Reverse**” inputs.

See Section B on basic programming information. See Section C – Parameter Table for Parameter Setup and Section D – Parameter Descriptions for more options.

### E-2 3-Wire Start/Stop Control Circuit (Standard Run)

The 3-wire Start/Stop control uses the “**FWD**” input (a momentary N.O. contact) as the “**START**” input. The “**STOP**” command is a N.C momentary contact. The speed is set by a pot in this example.

Options: Jog input; E Stop (should be NC); and FWD/REV directional input.

#### 3-Wire Start/Stop Control Wire Connection Diagram

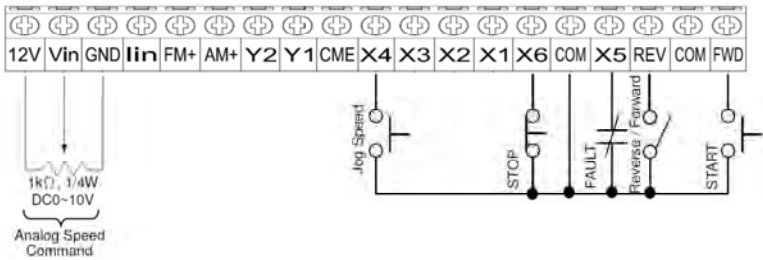

**Terminal and Function Setup Table**

Function	Value	Drive Terminal	Descriptions
F_001	1	<b>FWD</b>	<b>START:</b> Press “ <b>START</b> ” push-button t with the “ <b>Forward/Reverse</b> ” contact “Open” <b>STOP:</b> Press “ <b>STOP</b> ” push-button
		<b>REV</b>	<b>START:</b> Press “ <b>START</b> ” push-button with the “ <b>Forward/Reverse</b> ” contact “Closed” <b>STOP:</b> Press “ <b>STOP</b> ” push-button to open the circuit and motor stops
F_002	0	<b>Vin</b>	Set speed input by a POT via <b>Vin</b>
F_017	6	<b>X4</b>	<b>Default</b> – Jog speed = 6Hz. Jog speed can be changed if needed
F_031	60		<b>Default</b> – Max output frequency = 60Hz for a POT input
F_055	1	<b>X4</b>	Set Jog command input from terminal X4

## Section E Terminal Wiring Connection for Operation

Function	Value	Drive Terminal	Descriptions
F_056 (Optional)	-7	<b>X5</b>	Set Fault Input (Overload Relay)
F_057	0	<b>X6</b>	<b>Default</b> – Set STOP as normal closed set
F_124	1	<b>Vin</b>	<b>Default</b> – Vin input as speed command

**Note:**

1. If the Jog is used, it will over ride the Pot input as long as the jog is “set”.
2. For speed input from the keypad – Set F\_002 to “1”.
3. See Section B on basic programming information. See Section C – Parameter Table for Parameter Setup and Section D – Parameter Descriptions for more options.

### E-3 2-Wire Circuit for 3-Preset and Analog Speed Control

This circuit setup allows a user to select 3 preset speeds with 2 wire inputs. Optional directional input and speed control from a speed Pot.

#### 2-Wire Circuit for 3-Preset and Analog Speed Wire Connection Diagram

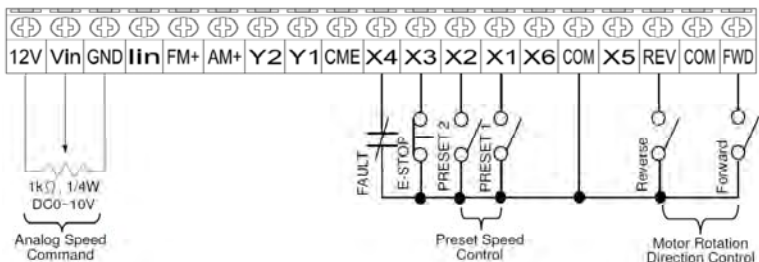

#### 2-Wire Circuit for 3-Preset and Analog Speed Function Setup Preset Speed Setting Table

X2	X1	Speed Command	Speed	Acc	Dec
Open	Open	Primary Speed	F_009	F_019	F_020
Open	Closed	Preset Speed 1	F_010	F_021	F_022
Closed	Open	Preset Speed 2	F_011	F_023	F_024
Closed	Closed	Preset Speed 3	F_012	F_025	F_026

**Note:** For more preset speed parameter setup and explanation, please see Section C-2 (Preset Speeds) and C-3 (Acceleration/Deceleration)

## Section E Terminal Wiring Connection for Operation

### Preset Speed Input and Function Setup Table

Function	Value	Drive Terminal	Descriptions
F_001	2	<b>FWD</b>	<b>START:</b> Press "RUN" with the <b>Forward</b> contact Closed and the <b>Reverse</b> Open <b>STOP:</b> "Forward" and "Reverse" contacts are Open, the motor Stops
		<b>REV</b>	<b>START:</b> Press "RUN" with the <b>Reverse</b> contact Closed and the <b>Forward</b> Open <b>STOP:</b> "Reverse" and "Forward" are open motor Stops
F_002	0		Set speed input by a POT to Vin
F_052	3	<b>X1</b>	<b>Default</b> – Define <b>X1</b> terminal as Preset-speed level 1
F_053	4	<b>X2</b>	<b>Default</b> – Define <b>X2</b> terminal as Preset-speed level 2
F_054 (Optional)	-9	<b>X3</b>	Set E-Stop as normal closed set
F_055 (Optional)	-7	<b>X4</b>	Set Fault (Overload Relay) as normal closed set
<b>Note:</b>			
<ol style="list-style-type: none"> <li>1. Primary speed is when both <b>X1</b> and <b>X2</b> are Open, the motor runs at primary speed as set in parameter F_009.</li> <li>2. When Forward and Reverse contacts are "<b>Closed</b>" at the same time, motor stops and drive displays "<b>dtF</b>" (<b>Direction command error</b>).</li> <li>3. When Forward and Reverse contacts are "<b>Open</b>" at the same time, motor stops and drive displays "-----" (<b>No direction command input</b>). For all preset speed and accel/decel time settings (preset speed setting table), see Section E-1 and Section C-2 for all settings.</li> <li>4. Analog speed input will <b>NOT</b> be active when the preset speed inputs – <b>PRESET1</b> and <b>PRESET2</b> are active.</li> <li>5. See Section B on basic programming information. See Section C – Parameter Table for Parameter Setup and Section D – Parameter Descriptions for more options.</li> </ol>			

## Section F Troubleshooting

### F-1 The Difference Between Faults and Warnings Message

**Warnings** – Are messages that do not require “Reset” and do not interrupt the drive’s Operation

**Faults:** Messages indicating a problem with the drive or the attached load requiring the drive’s output to be turned “OFF” and will not allow the drive to restart till “Reset” or the “Auto Restart” is programmed.

### F-2 Troubleshooting Fault and Warning Messages

#### 1. Over Current Fault

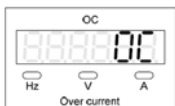

Keypad Display: OC

Drive’s output current has exceeded 220% of the drive rated current detected by the current sensor. Once the current limit is reached, the drive will shut “off” the output and display the “OC” Fault code. This is a Hardware fault so there are no parameters to adjust.

#### Suggestions

- Verify the drive is the correct size for the motor.
- Confirm wiring from the drive to the motor.
- Confirm motor leads are connected for the correct operating voltage as shown on the drive nameplate
- Verify if the drive parameter settings F\_034 (Base Frequency) and F\_035 (Base Voltage) have accidentally been changed.
- If there is a contactor or switch on the output of the drive, confirm that it is not operating after the drive output is turned “ON”.

#### 2. Over Voltage Fault

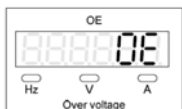

Keypad Display: OE

When the DC Bus exceeds the maximum voltage, the drive will fault and display “OE”. The DC Bus max voltage:

230VAC drives - 410Vdc.

460VAC drives - 820Vdc

This is a hardware fault so there is no parameter to adjust. The DC Bus voltage is from high line voltage or from an overhauling motor creating high voltage on the Bus. To monitor the DC Bus voltage set F\_006 to “4”.

#### Suggestions:

- Check the incoming line voltage is when in the drive specification
- If the drive trips on deceleration -Increase the decel time.
- If the fault is occurring during deceleration and the decel time cannot be extended, consider adding additional regen resistor (see Appendix)

### 3. Ground Fault

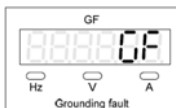

#### Keypad Display: GF

If the three phase output current monitor detects one phase to be unbalanced, the drive output will turn "Off" and the keypad will display "GF". This is a hardware fault so there is no parameter to adjust.

#### Suggestions

- The most common reason for this fault is a motor winding failure due to corona. Generally the drive can be reset and run for a period before another trip again with the "GF" Fault. To determine if it is a winding failure, use a "High Impedance Meter" to measure the motor insulation impedance (good insulation impedance must be between 50M $\Omega$  to 100M $\Omega$ ). If impedance is below 50M $\Omega$ , the motor needs to be replaced or rewound. If the motor is replaced, be sure to reduce the chance of the new motor failure by adding a reactor or take other actions to reduce "ring up" or "corona".
- Verify lead wires are not shorted from drive to motor.

### 4. Motor Overload Fault

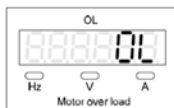

#### Keypad Display: OL

The drive has a built in Overload Relay which is calibrated by F\_048. This should be set for the motor Full Load Amps (FLA). If the drive current is above motor FLA, the drive will trip similar to a mechanical motor overload relay operating curve. The time before tripping is based on the level of current above the F\_048 setting.

#### Suggestions

- Verify the motor FLA at F\_048 is correct for the attached motor.
- Reduce the motor load.
- Confirm the motor leads connected properly
- Confirm parameter settings F\_034 (Base Frequency) and F\_035 (Base Voltage) was not changed by mistake.
- Confirm the motor and drive nameplate Voltage is the same.

### 5. Drive Overload Fault



Keypad Display: OL1

If the drive current operates at 150% of the drive rating for 1 minute, the drive will fault and display "OL 1". This is a hardware setting so there is no parameter to adjust.

#### Suggestions

- Verify the drive and motor correctly sized.
- Confirm parameter setting F\_034 (Base Frequency) and F\_035 (Base Voltage) was not changed by mistake and as same as motor and drive nameplate voltage and Frequency.
- Confirm motor rotation; check for mechanical obstructions such as belts over tightened or gearboxes not properly aligned.

### 6. Over Heating Fault



Keypad Display: OH

The drive thermal sensor has exceeded 85°C and has shut "off" the output and displayed "OH" on the keypad. This is a hardware fault so there is no parameter to adjust.

#### Suggestions

- Check the drive's cooling fans mounted on the heat sink are operating. If not replace the fan(s).
- If the drive is mounted in an enclosure, confirm proper ventilation. Max ambient is 50°C or 122°F.
- Verify other equipment heat is not being exhausting in to the drive.

### 7. Low Voltage Warning

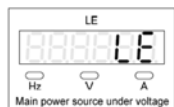

Keypad Display: LE

When the drive DC bus voltage drops to 33% and the drive **is not in operation**, the keypad will display the "LE" warning. This display will be seen each time the drive is powered down just before the keypad turns "off".

**Note: This is not a Fault so reset is NOT required.**

### Suggestions

- Confirm the input voltage on all three phases
- Confirm proper power input connections
- Confirm the drive voltage rating is correct

### 8. Low Voltage Fault

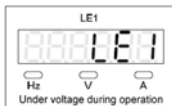

Keypad Display: LE1

When the drive detects the line voltage **below 67%** during operation, the drive will shut “off” the output and the keypad will display the “LE1” Fault code. This is a hardware fault so there is no parameter to adjust.

### Suggestions

- Confirm the input voltage on all three phases
- Confirm proper power input connections
- Confirm the drive voltage rating is correct

### 9. EEPROM Fault



Keypad Display: EEr

The Drive microprocessor can no longer communicate properly with the EEPROM so the drive will shut “off” the output and display fault message of “EEr”.

### Suggestion

- The normal cause for this fault is board damage. Recycle power to the drive and if the fault is still present - replace the control board or drive.

### 10. Output Interrupt Warning

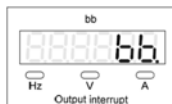

Keypad Display: bb

An Input terminal X1 – X6 (parameter F\_052 thru F\_057) has been programmed to “8” or “-8” for “Output Interrupt”. When that input is “set”, the drive will turn “off” with the keypad displaying the “bb” fault. The motor will coast to stop once the input is “set”. **Note:** this is a “Warning” so drive reset is not required. Once the input has been “released”, the drive output will return to the commanded output. To clear the warning, release the input and the drive will be “re-enabled” to the commanded speed.

### Suggestions

- This warning is only displayed if programmed. If this warning is not expected, then change parameters F\_052 – F\_57 from “8” or “-8”.
- To aid in troubleshooting, the inputs using F\_006 to “8” set the display to show “input” status. Confirm if the input is working correctly as seen by the drive display (please see F-4 to confirm each input terminal status)
- If the input is operating reverse of expectations, check the parameter F\_052 – F\_057 to see if it set to “8” or “-8”. The “8” setting means the drive will display the Warning on input “closing” and a “-8” means the input will set on input “opening”.

### 11. Over Voltage at Stop – Fault

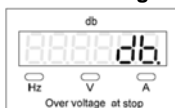

Keypad Display: db

When the drive detects the DC bus voltage over the programmed voltage level while the drive is NOT in operation, the keypad will display “db”. This is a hardware fault and there is no parameter to adjust. **Warning:** Disconnect the drive from the line to prevent damage to the drive or to the regen resistor. To monitor the bus voltage, set Parameter F\_006 to “4”.

Note: Drive programmed maximum voltage level  
230V series – Max DC bus voltage 385V  
460V series – Max DC bus voltage 785V

**Suggestions:** This is a high line voltage issue

- Check the line voltage and three phase line voltage balance.
- Confirm the drive is the correct voltage.

### 12. Direction Error Warning



Keypad Display: dtF

The drive has received a “Forward” and “Reverse” input at the same time. This is a “Warning” so the drive does not need to be “Reset”. The message will disappear once the drive has only one direction input.

**Note:** The drive will not start if it is at “stop” nor will it change directions till the conflict is resolved.

### Suggestions

- Verify inputs by changing the display to see input status by changing F\_006 to “8” (see F-4 to confirm input).
- Verify the input terminals are programmed correctly (terminals X1 – X6 and parameter F\_052 thru F\_057)

### 13. Free Run – Warning

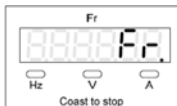

#### Keypad Display: Fr

The “Free Run” input has been “set” and the motor will “coast” to stop. This is not a fault so the drive does not need to be reset. To clear the display the Input must be “released”.

#### Suggestions:

- If this operation was not expected, an input terminal X1-X6 was changed using F\_052-F\_057 to “9” or “-9”. To help in troubleshooting, use the keypad display input monitoring mode by setting F\_006 to “8” to check if an input terminal X1~X6 has an input.

### 14. External Fault



#### Keypad Display: thr

This fault is programmed to an input. For the fault to display the input has been “set” causing the drive output to turn “off” and display “thr”. An input X1-X6 has been programmed for “External Fault” by the parameter from F\_052 to F\_057 set to “7” or “-7”. The default Input X5 parameter F\_056 is set to “7”. **Note:** Once the input is released then the drive still must be “reset” unless “auto-restart F\_080” has been programmed for all types of faults.

#### Suggestions

- If this operation was not expected an input terminal X1-X6 was changed using F\_052-F\_057 to “7” or “-7”. To help in troubleshooting use the keypad display input monitoring mode by setting F\_006 to “8”. (see F-4 to confirm input status) If the program input has been “set”, release the input to clear this fault.
- If the input is operating reverse of expectations, check the input that has been programmed for “External Fault”. If the setting is “7”, the drive will fault when the input is “set”. If the setting is “-7”, the drive will fault if the input is “opened”.

### 15. AD Converter Fault



#### Keypad Display: AdEr

The Analog to Digital converter of the CPU has failed. This is a hardware fault. Recycle the power to the drive allowing the drive to completely power down.

## Section F Troubleshooting

Upon powering up the AD fault reoccurrences, replace the control board or the drive.

### Suggestion:

- If the fault reoccurred during drive operation, check for high voltage wiring near input/output terminal wiring. If this is found separate, and recycle power.

### 16. Keypad Interrupt – Warning



#### Keypad Display: Err 00

The drive has lost communications to the keypad but the drive is not enabled.

### Suggestions

- This is normally a wiring issue between the keypad and CPU board. Confirm the cabling and keypad is properly seated. If reinserting the cable does not clear the display replace the cable.

### 17. Keypad Interrupt during Operation Fault

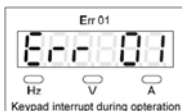

#### Keypad Display: Err 01

The drive has lost communications to the keypad while operating.

**Note:** The drive output will continue even under this fault

### Suggestions

- This is normally a wiring issue between the keypad and CPU board. Confirm the cabling and keypad is properly seated. If reinserting the cable does not clear the display replace the cable.

### 18. Write to Drive Fault



#### Keypad Display: Wr\_F

The program download from the keypad to the drive was not successful.

### Suggestions

- Verify the software versions are the same for both drives
- If the software versions are the same, confirm the cable connections between the keypad and the drive and try the download again.
- If the cable connection is ok but the program still cannot be downloaded, check the parameter setting F\_134. See B-5.4 for instructions

### F-3 Additional Issues and Suggestions

**No Display** - Power has been applied but the Display does not illuminate

**Suggestions:**

- Confirm Power to ALL three phases L1, L2 and L3.
- Confirm Power is not attached to the T1, T2, T3. **Warning:** this can cause the damage to the drive so **immediately** remove power and reconnect to L1,L2 and L3.
- Confirm Drive is correct rating for the line voltage
- Check Keypad interface Cable
- Check for the following voltages – if they are not present the drive is faulty
  - Bus Voltage on the DC Power Terminals
  - Control Voltage present
  - Analog Voltage control terminals

**Motor does not Rotate** - There are three areas to check  
Motor, Control wiring, Programming

**Suggestions for the Motor – making noise but not rotating.**

If the motor is making noise then power is getting to the motor.

- Check the connections in the motor terminal box are correct and for the right voltage.
- Confirm the wiring from the drive to the motor is correct.
- The power leads are correct and there is power going to the load then disconnect the load from the motor and try running the motor. If the drive rotates motor unloaded then load needs to be confirmed.

**Suggestions for the motor – motor not making noise.**

If there is no noise in the motor confirm voltage at the T1, T2, and T3. If there is not power to the motor then the drive is not working or the drive has not been correctly programmed or wired.

**Suggestions for Confirming Wiring-** Use F\_006 “8” (See F-4)

Using the keypad confirm wiring to the inputs.

**Note:** Once the wiring has been confirmed then the programming needs confirmation that it was programmed correctly.

**Suggestions for confirming the Program**

- Reconfirm each Input program setting F\_052 thru F\_057. **Note:** the Parameter setting can be either a “+”, or a “-”
- If used confirm the Analog Input. **Note:** the Default on the drive is for a Current input so if a pot input is connected SW1 must be changed (See A-3).

## Section F Troubleshooting

**Final Suggestions** – if the motor wiring and software seem to be correct and still no motor rotation. Disconnect all control wiring and reset the drive using F\_134.

- Confirm the drive will operate the motor. If not the motor load is too much, the motor is not connected correctly. Confirm by disconnecting the motor from the load
- If the motor did rotate - then program and input connections are the issue. Reconfirm program and wiring.

**Drive operation does not operate consistently having trips stops for no reason or speed oscillates.**

These are signs of high voltage AC noise on the Low Voltage input to the drive.

**Suggestions:**

- Snub all relay and contactor coils
- Confirm all control wiring cross high voltage at 90° from each other.
- Confirm the input wires are not in the same raceway or conduit as the input or output wires.
- Confirm control wires shield are connected at only one end and to the drive common or ground for that input.

### F- 4 Digital Input and Output Diagnostic Tool

This display will confirm what the drive actually sees for each digital input and show if the digital output has been “set” or is “open”. Set F\_006 to “0” –see also B-3

Digital Input and Direction Terminals

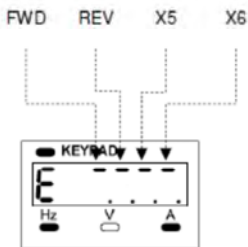

Digital Output Terminals

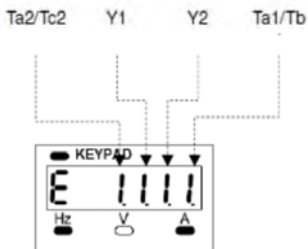

Digital Input Terminals

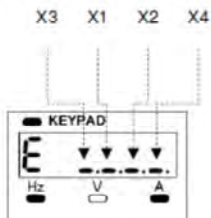

**Note:**

- Terminal Status Display displays the terminal signal status when a wire properly connects to the terminal.
- If a wire is properly connected to a terminal, the keypad display under Terminal Status Display shows “-” or “1” when the input or output terminal has a signal

### A1-1 Keypad Drawings

#### WWE-201KP Keypad

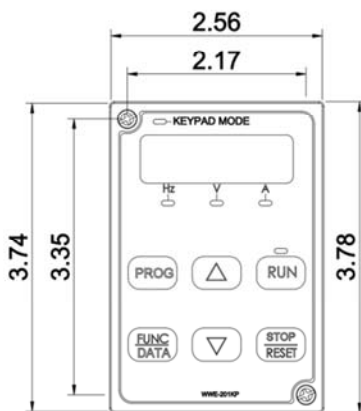

WWE-201KP

### A1-2 Drive Outline Drawing

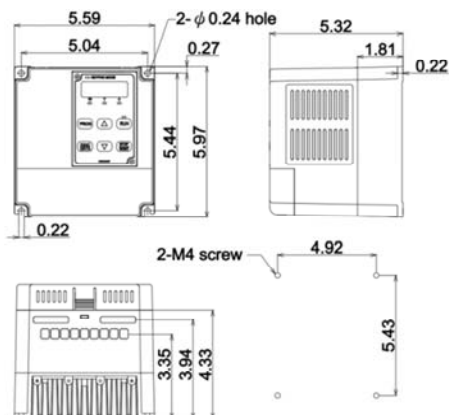

**A1-3 Drive Outline Drawing with NEMA1 Enclosure**

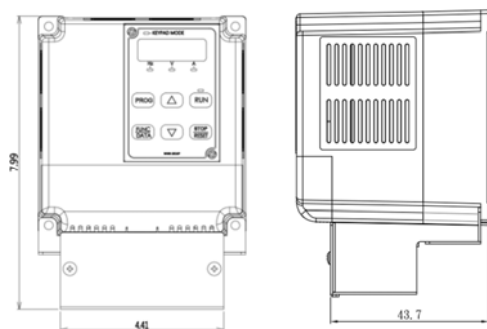

**A1-4 Dimensions for Mounting WWE-201KP – Keypad**

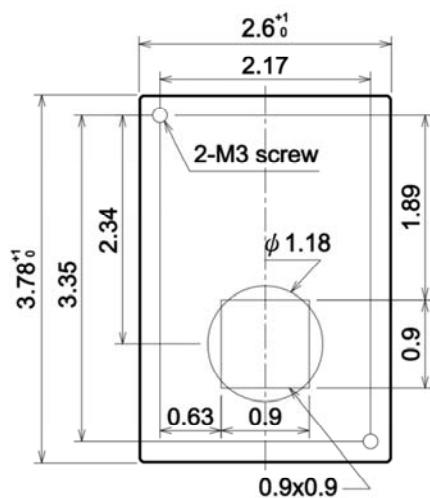

A1-5 Keypad Door Mount – A01

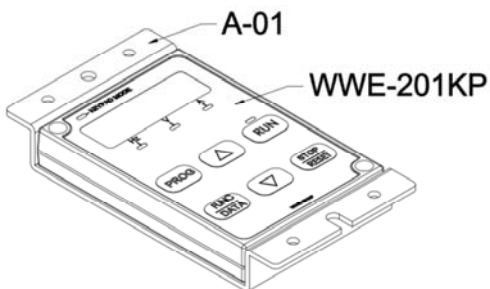
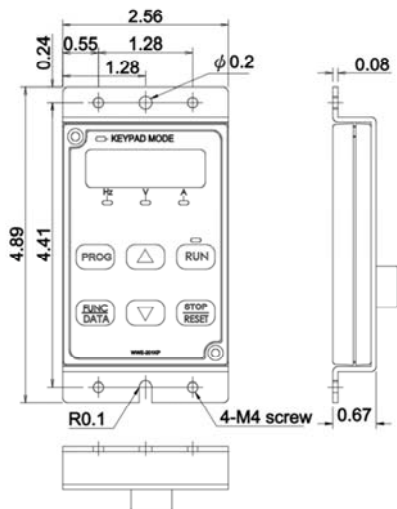

### A2-1 Resistor Values for External Brake Resistors

#### AC 230V Input

Model Number	Minimum Specification	Standard Brake Resistor	Approx. Braking Torque (10%ED)
WWEVFD-12-230	100Ω	MHL100-100*1pc	240
WWEVFD-1-230			140
WWEVFD-2-230			75
WWEVFD-3-230	40Ω	MHL500- 40*1pc	160
WWEVFD-5-230			105

#### AC 460V Input

Model	Minimum Specification	Standard Brake Resistor	Approx. Braking Torque (10%ED)
WWEVFD-1-460	400Ω	MHL100- 400*1 pc	145
WWEVFD-2-460	200Ω	MHL100- 400*2pcs in parallel, total 200W	180
WWEVFD-3-460	133Ω	MHL100- 400*3pcs in parallel, total 300W	180
WWEVFD-5-460	100Ω	MHL100- 400*4pcs in parallel, total 400W	160

#### Calculating Braking Requirements

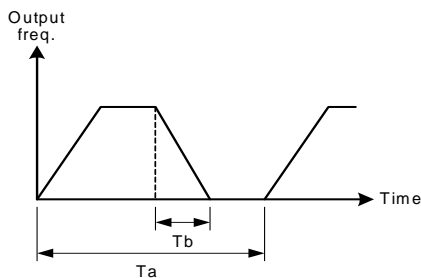

※Note:

- %ED (Effective Duty cycle) =  $T_b / T_a \times 100(\%)$   
(continuous operation time  $T_b < 15$  sec).  
The definition is as shown in a figure right.
- Above watts of table is defined at 10%ED.
- 230V series drive or DBU braking activation voltage is DC 400V.  
460V series drive or DBU braking activation voltage is DC 800V.

### A2-2 Dynamic Brake and Resistor

A. Brake transistor can be installed in the following models:  
 Standard build-in: WWEVFD-12-230~WWEVFD-15-230 and  
 WWEVFD-1-460~WWEVFD-20-460.

B. Brake resistor outline (option)  
 Aluminum case resistor

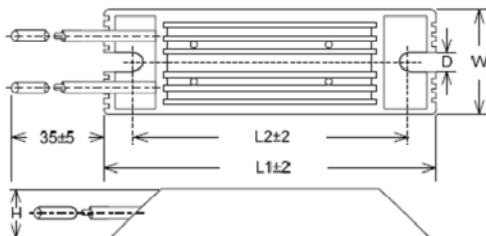

Model	Specification	Dimensions (mm)					Max. Weight (g)
		L1	L2	W	H	D	
MHL100-100	100W/100Ω	165	150	40	20	5.3	200
MHL500-40	500W/40Ω	335	320	60	20	5.3	1100

Notes:

1. When install the brake resistor or dynamic brake unit, please set F\_093 (AVR) to "0".
2. When the braking is frequently applied, please increase the resistor wattage and add the cooling fan to prevent the resistor overheating.
3. Please use the heat-resistant wire for the brake resistor wiring.

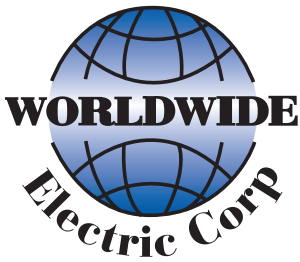

# **EFFICIENCY SERIES**

**WWEVFD-010111**  
**January 1, 2011**